

EURO-BEARINGS LTD

LINEAR BEARINGS & HOUSINGS



www.euro-bearings.com

Tel. 01908 511733

email: sales@euro-bearings.com

GENERAL INFORMATION

Introduction

Ball bushings are anti-friction bearings for linear motion. They offer the familiar advantages of ball bearings. e.g. Long service life, high precision and efficiency.

General Information

NB Ball Bushings are manufactured in Japan by Nippon Bearing Co. which is one of the largest Japanese Ball Bushing manufacturers. All of the shafts, rails and housings shown in this catalogue are manufactured in Germany. All parts are normally on short lead times (less than 7 days).

Construction and Materials

The outer ring of the ball bushing is made from hardened rolling bearing steel. The cylindrical ground and precision formed cage is made from one single part and is held in position by solid steel endplates. This design saves, in many applications, the use of sealed ball bushings. The special features of these extremely robust units are high rigidity, reliability and durability, especially during assembly.

Speed, Lubrication and Friction

The coefficient of friction μ of NB ball Bushings without seals is very low, approximately 0.001 to 0.003. Standard lubrication practices as applied to anti-friction bearings can be used for all ball bushings. Either oil or grease can be used as a lubricant but in most cases grease is preferable. If necessary NB ball bushings can be used without lubrication. Speeds of up to 2 m/s and accelerations of up to 60 m/s² are generally safe.

Mounting

When mounting a standard ball bushing into a housing an H7 fit for the housing bore is generally required. The ball bushing is secured in the housing by retaining rings, fixing screws or adhesive. To achieve pre-load the recommended tolerance for the housing bore can be, in certain cases, JS6 to M6.

Using our housings guarantees best fit and repeatability.

Life expectancy (Load capacity and calculation)

The size of the ball bushing is dictated by its load bearing capacity and its life expectancy. The nominal life span is calculated using this formula:

$$L = \left(\frac{C}{F} \right)^3 \cdot 10^5 m$$

where:
 C = Dynamic load capacity taken from the tables in this catalogue
 F = Dynamic equivalent load
 L = Travel in metres

For more precise calculations some other factors need to be included:

f_H = Shaft hardness (When using our shafts the factor is 1. For other shafts see table below)

f_T = factor for Temperature. An allowance must be made when operating at higher temperatures (i.e. >80° C) – see table below

f_L = factor for Life. See chart below if exceeding 10⁵m of travel

Therefore:

$$L = \left(\frac{C}{F} \cdot f_H \cdot f_T \cdot f_L \right)^3 \cdot 10^5 m$$

Factors		1	0.9	0.8	0.7	0.6	0.5	0.4	0.3	0.2	0.1
f_H	Hardness HRC	60	56	55	54	52	49	46	42	33	20
f_T	Temperature	80	100	125	160	200	on demand				
f_L	Travel life	1	1.3	2	3	5	8	15	35	120	1000

STANDARD BALL BUSHINGS

NB Ball Bushings are available as Closed Type NB0.- (with fixed working bore diameter) or Adjustable NB1.- (slotted) type ball bushings.

Cages:

These ball bushings are supplied with a steel cage as standard and held in position with solid steel end plates. Alternatively they can be supplied with a plastic cage using part number NB.0-3..

Seals:

Steel Cage, without seals. Ordering reference: NB.0-0..

Steel Cage, with two seals. Ordering reference: NB.2-0..

(where .. = shaft diameter)

eg. NB00-020 is unsealed with a steel cage; NB02-320 is sealed with a plastic cage



Closed type
NB0.-...

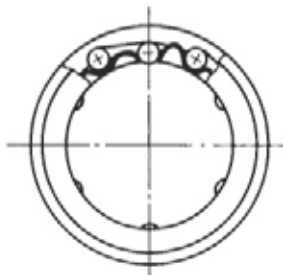

Slotted (adjustable) type
NB1.-...

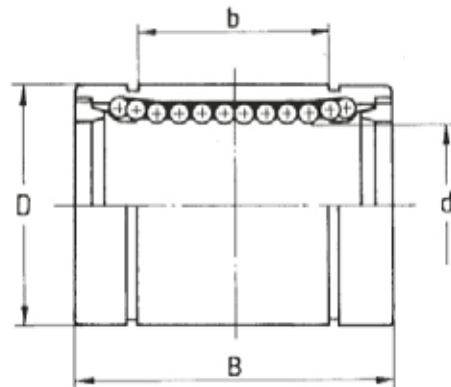
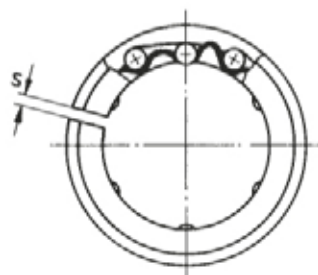

Closed Type	Adjustable Type	d	D	B	b	s	Ball Circuits	Load C (N)	Load C ₀ (N)	Weight (kg)
NB00-005	NB1.-305	5	12	22	12	1	4	210	270	0.01
NB00-008	NB1.-308	8	16	25	14	1	4	280	420	0.02
NB00-010	-	10	19	29	19	1	4	380	560	0.03
NB00-012	NB1.-012	12	22	32	20	1.5	4	570	800	0.04
NB00-016	NB1.-016	16	26	36	22	1.5	4	800	940	0.06
NB00-020	NB1.-020	20	32	45	28	2	5	900	1450	0.10
NB00-025	NB1.-025	25	40	58	40	2	6	1100	1700	0.24
NB00-030	NB1.-030	30	47	68	48	2	6	1700	3000	0.36
NB00-040	NB1.-040	40	62	80	56	3	6	2300	4700	0.77
NB00-050	NB1.-050	50	75	100	72	3	6	4100	8300	1.20
NB00-060	NB1.-060	60	90	125	95	3	6	4800	10200	2.30
NB00-080	NB1.-080	80	120	165	125	3	6	7500	16300	5.20

The load capacity listed in the above table is only valid if the direction of the load is acting directly on the ball race. If the direction of load is acting between two ball races the load rating is multiplied by the factor f.

For sizes 5,8,10,12 & 16, f = 1.41 for size 20 f = 1.46 and for sizes 25 to 80 f = 1.28

SPECIAL BALL BUSHINGS

Special Ball Bushings are identical in construction and materials to the standard ball bushings.

Some of these are dimensionally different to ISO 10285 and the European Standard.

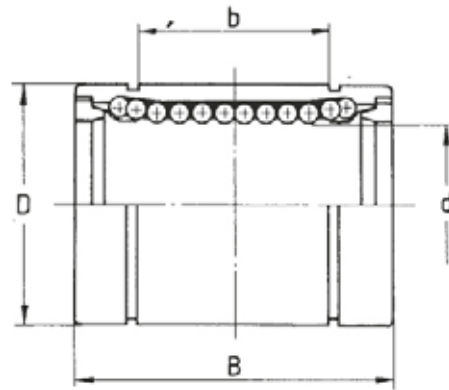
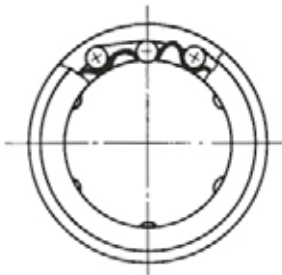

PART (no seals)	PART (2 seals)	d	D	B	b	Ball Circuits	Load C (N)	Load C ₀ (N)	Weight (kg)
NB00-003	NB02-003	3	7	10	-	4	70	100	0.002
NB00-004	NB02-004	4	8	12	-	4	90	130	0.002
SB00-005	SB02-305	5	10	15	8	4	170	210	0.010
NB00-006	NB02-306	6	12	19	11	4	210	270	0.010
SB00-008	SB02-308	8	15	24	15	4	280	400	0.020
SB00-035	SB02-335	35	52	70	45	6	1700	3200	0.400
NB00-100	NB02-100	100	150	175	117	6	14400	35500	8.400
SB00-120	SB02-120	120	180	200	150	8	16700	40800	15.000
SB00-150	SB02-150	150	210	240	160	8	21500	55400	20.200

The load capacity listed in the above table is only valid if the direction of the load is acting directly on the ball race. If the direction of load is acting between two ball races the load rating is multiplied by the factor f. For sizes 3,4,5,6 & 8, f = 1.41 for size 35 & 100 f = 1.28 and for sizes 120 & 150 f = 1.12

OPEN BALL BUSHINGS

NB Open Type Ball Bushings are available with a steel cage as standard which is held in position by solid steel end plates.

Steel Cage, without seals. Ordering reference NB30-0..

Steel Cage, with two seals. Ordering reference NB32-0..

(where ...= shaft diameter)

The bushes can be supplied with a fixing hole and then the bush can be retained in our housings using the fixing screws (supplied with housings)

Fixing screw with nipple:

Shaft sizes 12 to 40: M4

Shaft sizes 50 to 80: M5

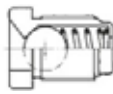

	SW	D	d	h
HS12-40	6	M5	3,5	11
HS50-80	7	M6	4,5	15

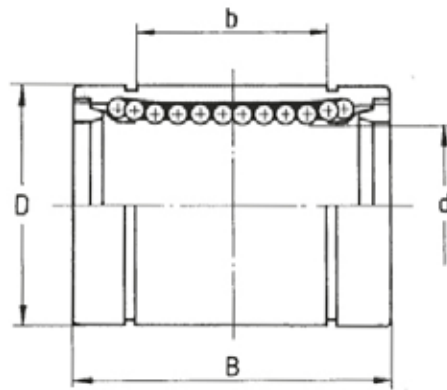
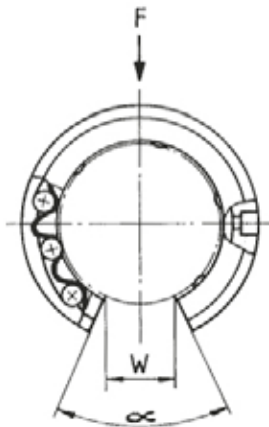

PART (no seals)	PART (2 seals)	d	D	B	b	W	a	Ball Circuits	Load C (N)	Load C ₀ (N)	Weight (kg)
NB30-012	NB32-012	12	22	32	20	7.5	78	3	570	800	0.03
NB30-016	NB32-016	16	26	36	22	10	78	3	800	940	0.05
NB30-020	NB32-020	20	32	45	28	10	60	4	900	1450	0.08
NB30-025	NB32-025	25	40	58	40	12.5	60	5	1100	1700	0.19
NB30-030	NB32-030	30	47	68	48	12.5	50	5	1700	3000	0.30
NB30-040	NB32-040	40	62	80	56	16.8	50	5	2300	4700	0.60
NB30-050	NB32-050	50	75	100	72	21	50	5	4100	8300	0.97
NB30-060	NB32-060	60	90	125	95	27.2	54	5	4800	10200	1.90
NB30-080	NB32-080	80	120	165	125	36.3	54	5	7500	16300	4.38

The load capacity in the above table is only valid if the direction of the load F is acting vertically. If the load is acting from another direction the load rating must be multiplied by the factor f taken from the diagrams below:

12 & 16 mm

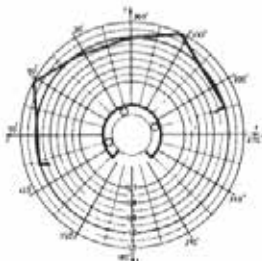

20 mm

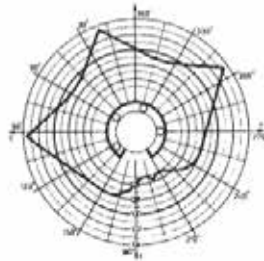

25 to 80 mm

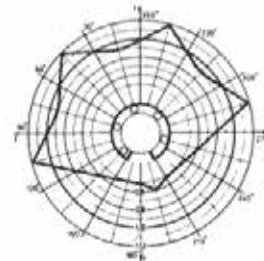

STAINLESS STEEL BALL BUSHINGS

These stainless steel ball bushings have the same boundary dimensions & tolerances as the standard ball bushings (open & closed).

They are used where corrosion resistance is required for example in the food and chemical industries.

Technical specifications of the materials used:

Outer Ring & Balls 1.4125 (SUS440C)
 Steel Cage 1.4301 (SUS304)
 End Plates 1.4021 (SUS420)

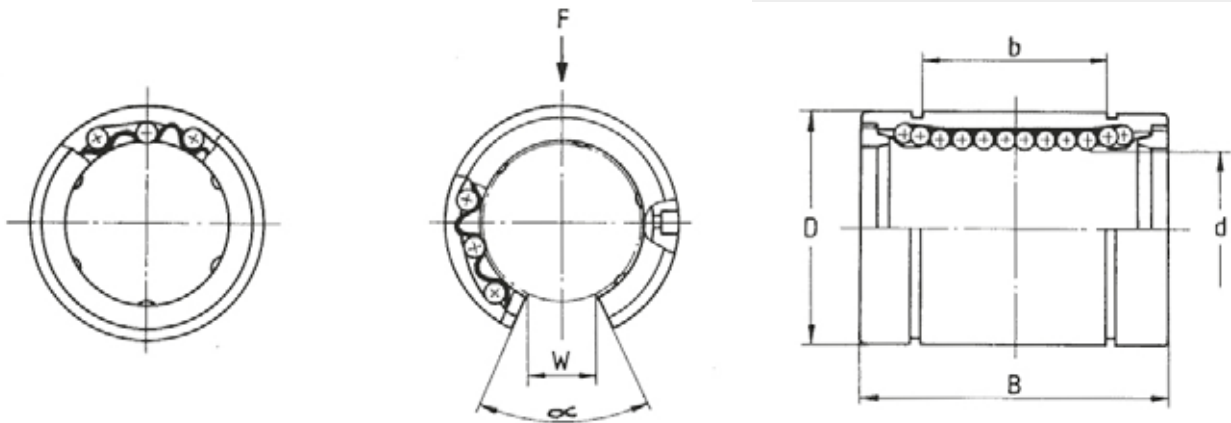

Closed Type	d	D	B	b	Ball circuits	Load C (N)	Load C ₀ (N)	Weight (kg)	Circlip Size
KB50-008	8	16	25	14	4	270	410	0.02	16x1
KB50-012	12	22	32	20	4	520	790	0.05	22x1.2
KB50-016	16	26	36	22	4	590	910	0.06	27x1.2
KB50-020	20	32	45	28	5	880	1400	0.10	33x1.5
KB50-025	25	40	58	40	6	1000	1600	0.24	42x1.75
KB50-030	30	47	68	48	6	1600	2800	0.36	48x1.75
KB50-040	40	62	80	56	6	2200	4100	0.77	62x2
KB50-050	50	75	100	72	6	3900	8100	1.25	75x2.5

KB50's also available for shaft sizes 3, 4, 5, 10 & 60. Please see website for details.

Open Type	d	D	B	b	alpha	W	Ball Circuits	Load C (N)	Load C ₀ (N)	Weight (kg)
KB53-012	12	22	32	20	78	7.5	3	520	790	0.04
KB53-016	16	26	36	22	78	10	3	590	910	0.05
KB53-020	20	32	45	28	60	10	4	880	1400	0.08
KB53-025	25	40	58	40	60	12.5	5	1000	1600	0.20
KB53-030	30	47	68	48	50	12.5	5	1600	2800	0.31
KB53-040	40	62	80	56	50	16.8	5	2200	4100	0.77
KB53-050	50	75	100	72	50	21	5	3900	8100	1.08

ECO BALL BUSHINGS

These high quality ball bushings conform to ISO 10285.

They consist of outer ring and balls made from hardened and ground steel 100Cr6 and the cage is made from poly-acetal.

Integral rubber wiper seals are fitted as standard.

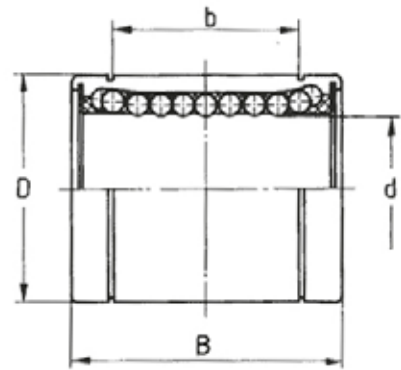
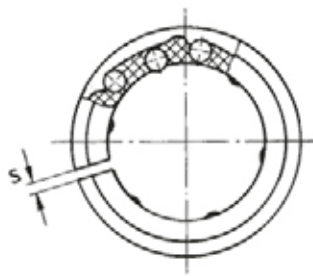
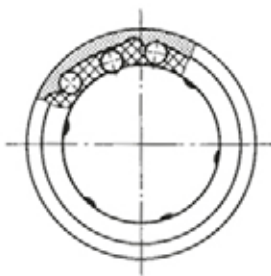

PART	d	D	B	b	s	Circuits	C (N)	C ₀ (N)	Weight (kg)
LME 8 UU	8	16	25	14	1	4	270	410	0.02
LME 12 UU	12	22	32	20	1.5	4	510	780	0.04
LME 16 UU	16	26	36	22	1.5	5	580	890	0.06
LME 20 UU	20	32	45	28	2	5	860	1400	0.09
LME 25 UU	25	40	58	40	2	6	980	1600	0.22
LME 30 UU	30	47	68	48	2	6	1600	2700	0.33
LME 40 UU	40	62	80	56	3	6	2200	4000	0.71
LME 50 UU	50	75	100	72	3	6	3800	7900	1.15
LME 60 UU	60	90	125	95	3	6	4700	10000	2.22

The load capacity listed in the above table is only valid if the direction of the load is acting directly on the ball race. If the direction of load is acting between two ball races the load rating is multiplied by the factor f. For sizes 5,8,12 f = 1.41, for sizes 16 & 20 f = 1.46 and for sizes 25 to 60 f = 1.28

Tel. 01908 511733

www.euro-bearings.com

EURO-BEARINGS LTD

OPEN ECO BALL BUSHINGS

These high quality open type ball bushings conform to ISO 10285.

They consist of outer ring and balls made from hardened and ground steel 100Cr6 and the cage is made from polyacetal.

Integral rubber wiper seals are fitted as standard.

Can be supplied with a fixing hole on request.

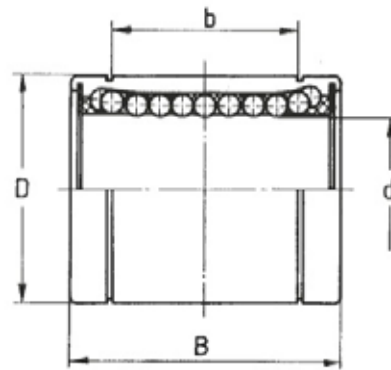
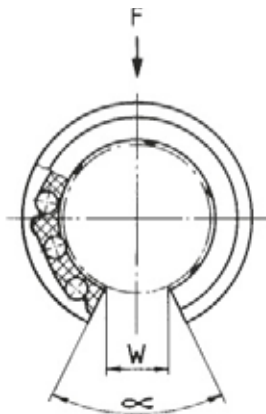

PART	d	D	B	b	W	α	Ball Circuits	Load C (N)	Load C ₀ (N)	Weight (kg)
LMEO-12UU	12	22	32	20	8	78	3	570	800	0.03
LMEO-16UU	16	26	36	22	10	78	4	580	870	0.05
LMEO-20UU	20	32	45	28	10	60	4	860	1400	0.08
LMEO-25UU	25	40	58	40	12.5	60	5	980	1600	0.19
LMEO-30UU	30	47	68	48	12.5	50	5	1600	2700	0.30
LMEO-40UU	40	62	80	56	16.8	50	5	2200	4000	0.60
LMEO-50UU	50	75	100	72	21	50	5	3800	7900	0.97
LMEO-60UU	60	90	125	95	27.2	54	5	4700	10000	1.90

The load capacity in the above table is only valid if the direction of the load F is acting vertically. If the load is acting from another direction the load rating must be multiplied by the factor f taken from the diagrams below:

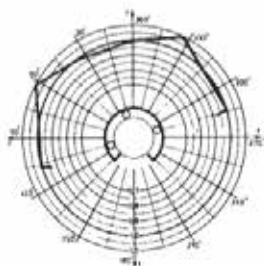

12 & 16 mm

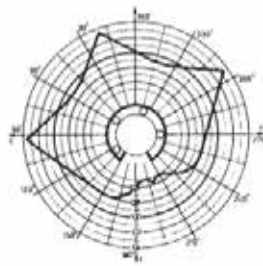

20 mm

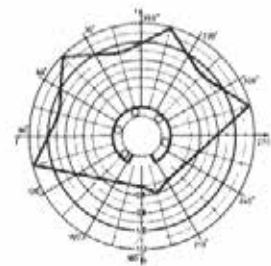

25 to 80 mm

SUPER BALL BUSHINGS

These ball bushings have the same boundary dimensions as the standard ball bushings and are usually interchangeable. The additional ball circuits enable higher load capacities.

Super ball bushings offer the advantage of being able to correct slight errors in alignment. The outer diameter varies along the length making them slightly barrel shaped. It is this shaping that enables it to self align.

The self alignment feature also means that there is no reduction in load capacity due to pressure between the bushing edge and the shaft. The ball tracks are ground and consequently the bushes run smoothly. Speeds of up to 3m/s are possible.

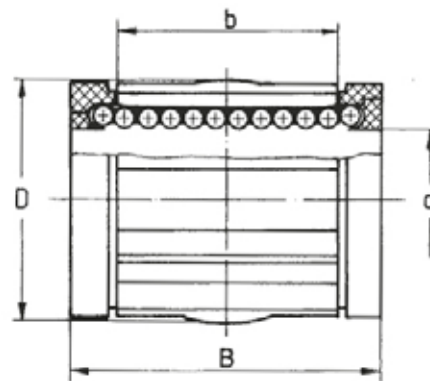
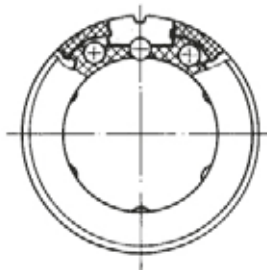

PART (2 seals)	d	D	B	b	Ball Circuits	Load C (N)	Load C ₀ (N)	Weight (kg)	Circlip Size
SK70-208	8	16	25	14.2	4	423	534	0.007	16x1
SK70-210	10	19	29	19	5	750	930	0.014	18x1.2
SK70-212	12	22	32	20	5	1020	1290	0.021	22x1.2
SK70-216	16	26	36	22	5	1250	1550	0.043	27x1.2
SK70-220	20	32	45	28	6	2090	2630	0.058	33x1.5
SK70-225	25	40	58	40	6	3780	4720	0.123	42x1.75
SK70-230	30	47	68	48	6	5470	6810	0.216	48x1.75
SK70-240	40	62	80	56	6	6590	8230	0.333	62x2
SK70-250	50	75	100	72	6	10800	13500	0.618	75x2.5

The load capacity listed in the above table is only valid if the direction of the load is acting directly on the ball race. If the direction of load is acting between two ball races the load rating is multiplied by the factor f.
For size 8 f = 1.41, for sizes 12 & 16 f = 1.46 and for sizes 20 to 40 f = 1.28.

OPEN SUPER BALL BUSHINGS

These ball bushings have the same boundary dimensions as the standard open ball bushings. They offer the same advantage of self alignment as the closed type Super Ball Bushings. An additional ball race in the larger ball bushings increases their carrying capacity slightly. The bushing is provided with a retention hole to secure it against displacement.

The load capacity shown in the table is only valid for load applied vertically. If the load is acting in any other direction, the load capacity must be taken from the diagrams shown below.

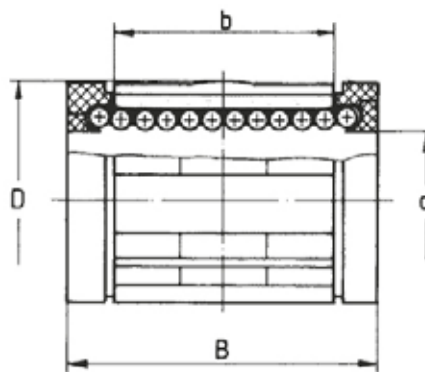
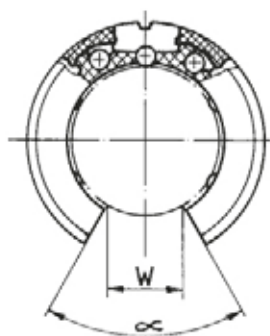

PART (2 seals)	d	D	B	b	w	α	Ball Circuits	Load C (N)	Load C ₀ (N)	Weight (kg)
SK71-212	12	22	32	20	6.5	66	4	1250	1620	0.017
SK71-216	16	26	36	22	9	68	4	1560	1930	0.035
SK71-220	20	32	45	28	9	55	5	2090	2630	0.048
SK71-225	25	40	58	40	11.5	57	5	3070	4720	0.103
SK71-230	30	47	68	48	14	57	5	5470	6810	0.177
SK71-240	40	62	80	56	19.5	56	5	6590	8230	0.275
SK71-250	50	75	100	72	22.5	50	5	10800	13500	0.520

Sizes 12 & 16 mm

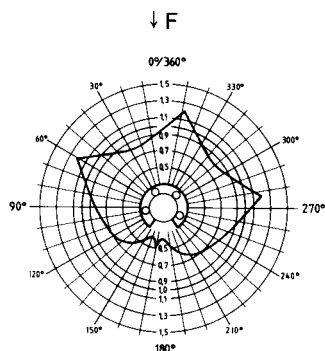

Sizes 20 to 50 mm

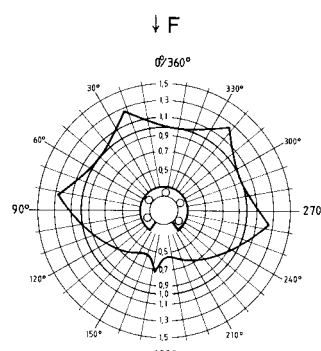

STAINLESS STEEL COMPACT BUSHINGS

These stainless steel compact ball bushings offer a fully re-circulating ball bushing in minimum space.

For housings to suit, see AG27- series. Use with hardened ground shaft and end support series WB58-

The bush is made from 1.4034 (DIN steel number) & the balls from 1.3541.

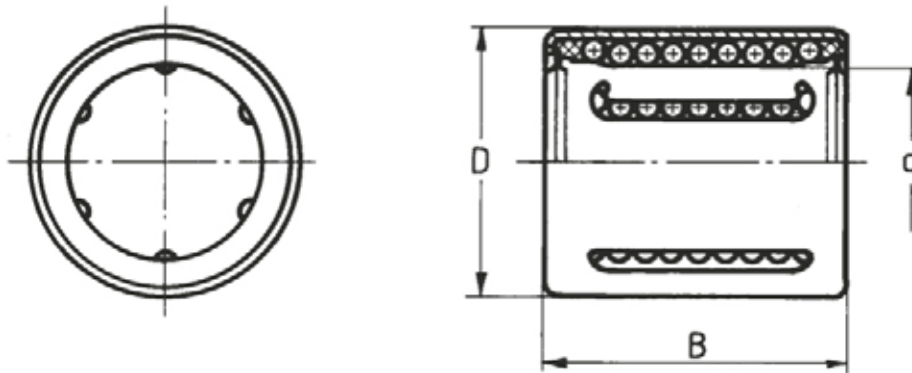

PART (Stainless Steel)	d	D	B	Ball Circuits	Load C (N)	Load C ₀ (N)	Weight (kg)
LBBRn206	6	12	22	4	400	240	0.007
LBBRn208	8	15	24	4	440	280	0.012
LBBRn210	10	17	26	4	500	370	0.015
LBBRn212	12	19	28	5	620	510	0.019
LBBRn214	14	21	28	5	710	530	0.021
LBBRn216	16	24	30	5	800	630	0.028
LBBRn220	20	28	30	6	950	800	0.033
LBBRn225	25	35	40	6	1990	1560	0.066
LBBRn230	30	40	50	7	2900	2700	0.095
LBBRn240	40	52	60	8	5100	4500	0.182
LBBRn250	50	62	70	9	6950	6300	0.252

Tel. 01908 511733

www.euro-bearings.com

EURO-BEARINGS LTD

ECO COMPACT BALL BUSHINGS

These compact ball bushings offer a fully re-circulating ball bushing in minimum space.

For housings to suit, see AG27- series. Use with hardened ground shaft and end support series WB58-

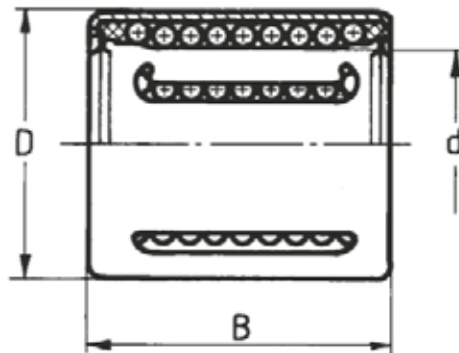
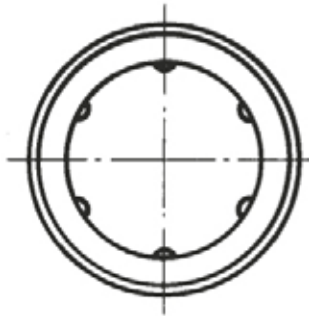

PART	d	D	B	C (N)	C ₀ (N)	Weight (g)
KH0622PP	6	12	22	400	240	7
KH0824PP	8	15	24	440	280	12
KH1026PP	10	17	26	500	370	14.5
KH1228PP	12	19	28	620	510	18.5
KH1428PP	14	21	28	710	530	20.5
KH1630PP	16	24	30	800	630	27.5
KH2030PP	20	28	30	950	800	32.5
KH2540PP	25	35	40	1990	1560	66
KH3050PP	30	40	50	2900	2700	95
KH4060PP	40	52	60	5100	4500	182
KH5070PP	50	62	70	6950	6300	252

ROUND FLANGED BALL BUSHINGS

Flanged ball bushings are a useful means of mounting a ball bushing. The flange and outer ring are made from one billet of steel thereby giving enormous strength to the design. These single ball bushings with round flange are available with seals (FK12-) or without seals (FK10-).

For extra smooth running, these ball bushings are available with a plastic ball retainer. Ordering reference FK12-3..

Certain sizes are also available in stainless steel - enquire using part numbers formulated with a -5 as the first digit of the second group of numbers. For example FK10-520.

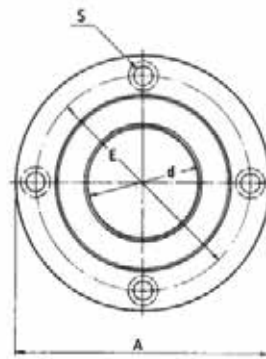
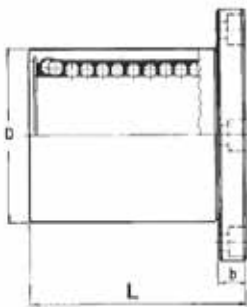

PART (no seals / all steel)	PART (2 seals / plastic cage)	d	D	L	b	A	E	S	Load C (N)	Load C ₀ (N)	Weight (kg)
-	FK12-305	5	12	22	5	28	20	M3	205	265	0.02
FK10-008	FK12-308	8	16	25	5	32	24	M3	280	410	0.04
FK10-012	FK12-312	12	22	32	6	42	32	M4	520	790	0.08
FK10-016	FK12-316	16	26	36	6	46	36	M4	790	1200	0.11
FK10-020	FK12-320	20	32	45	8	54	43	M5	900	1400	0.18
FK10-025	FK12-325	25	40	58	8	62	51	M5	1000	1600	0.34
FK10-030	FK12-330	30	47	68	10	76	62	M6	1600	2800	0.56
FK10-040	FK12-340	40	62	80	13	98	80	M8	2200	4100	1.18
FK10-050	FK12-350	50	75	100	13	112	94	M8	3900	8100	1.70
FK10-060	FK12-360	60	90	125	18	134	112	M10	4700	9800	3.22
FK10-080	FK12-080	80	120	165	18	164	142	M10	7400	16000	6.42

Tel. 01908 511733

www.euro-bearings.com

EURO-BEARINGS LTD

SQUARE FLANGED BALL BUSHINGS

These square flanged ball bushings are made to the European design and have the same characteristics and loadings as our popular range of round flanged ball bushings.

The flange provides a simple but robust mounting system. The ball bushing has 2 integral shaft wiping seals and a plastic cage.

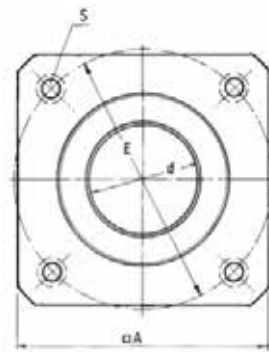
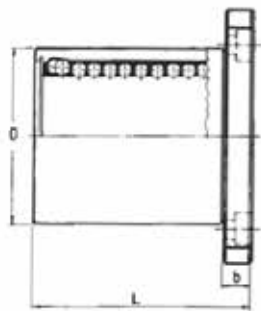

PART (2 seals)	d	D	L	b	A	E	S	Load C (N)	Load C ₀ (N)	Weight (kg)
LMEK08UU	8	16	25	5	25	24	M3	270	410	0.03
LMEK12UU	12	22	32	6	32	32	M4	520	790	0.07
LMEK16UU	16	26	36	6	35	36	M4	590	910	0.09
LMEK20UU	20	32	45	8	42	43	M5	880	1400	0.15
LMEK25UU	25	40	58	8	50	51	M5	1000	1600	0.30
LMEK30UU	30	47	68	10	60	62	M6	1600	2800	0.46
LMEK40UU	40	62	80	13	75	80	M8	2200	4100	0.99

TANDEM ROUND FLANGED BUSHES

The tandem round flanged ball bushings offer all the same benefits as the standard round flanged ball bushings but are longer and consequently have better load capacities.

They are available with seals (FK92-...) or without seals (FK90-...).

For all parts made from steel, the part number is FK90-0.. They are also available with two seals and a polyamide ball retainer - part number FK92-3.. (where .. is the shaft size).

Certain sizes are also available in stainless steel - enquire using part numbers formulated with a -5 as the first digit of the second group of numbers - for example FK90-520.

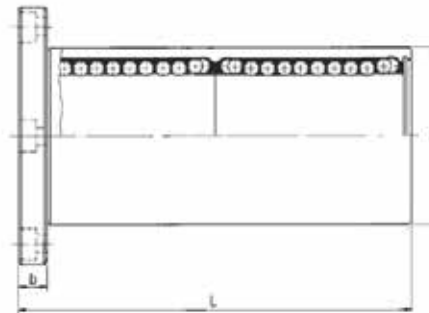
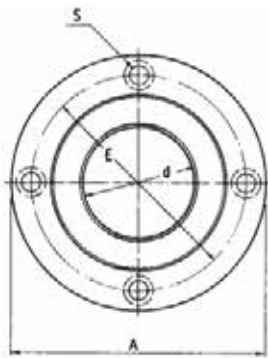

PART NO (2 SEALS)	d	D	L	b	A	E	S	Load C (N)	Load C ₀ (N)	Weight (kg)
FK92-308	8	16	46	5	32	24	M3	440	820	0.06
FK92-312	12	22	61	6	42	32	M4	830	1580	0.10
FK92-316	16	26	68	6	46	36	M4	1250	2400	0.17
FK92-320	20	32	80	8	54	43	M5	1430	2800	0.26
FK92-325	25	40	112	8	62	51	M5	1600	3200	0.52
FK92-330	30	47	123	10	76	62	M6	2550	5600	0.82
FK92-340	40	62	151	13	98	80	M8	3500	8200	1.80
FK92-350	50	75	192	13	112	94	M8	6200	16200	2.80
FK92-360	60	90	209	18	134	112	M10	7600	20000	2.82

TANDEM SQUARE FLANGED BUSHES

These tandem (i.e. double length) square flanged ball bushings are made to the European sizes and have the same characteristics and loadings as our popular range of round flanged ball bushings.

The flange provides a simple but robust mounting system. The ball bushing has 2 integral shaft wiping seals and a polyamide ball retainer.

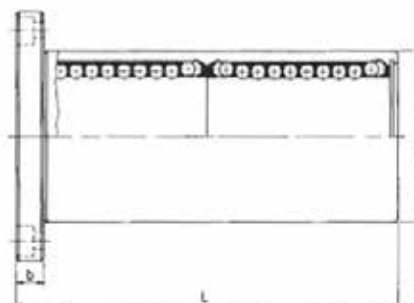
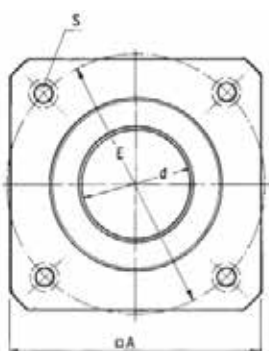

PART (2 seals)	d	D	L	b	A	E	S	Load C (N)	Load C ₀ (N)	Weight (kg)
LMTK08UU	8	16	46	5	25	24	M3	430	780	0.05
LMTK12UU	12	22	61	6	32	32	M4	655	1200	0.08
LMTK16UU	16	26	68	6	35	36	M4	1230	2350	0.16
LMTK20UU	20	32	80	8	42	43	M5	1400	2750	0.23
LMTK25UU	25	40	112	8	50	51	M5	1560	3140	0.47
LMTK30UU	30	47	123	10	60	62	M6	2490	5490	0.57
LMTK40UU	40	62	151	13	75	80	M8	3430	8040	1.38

TANDEM CENTRE ROUND FLANGED BUSH

Tandem Centre Flanged Ball Bushings are specially designed for applications where the shaft is perpendicular to the supporting surface of the bush. The ball bushing can be bolted on through the flanged and therefore there is no need for a housing.

These ball bushings are available with two seals and a polyamide ball retainer, which is secured in the bush through solid end plates. Ordering reference number TF02-3..

The ordering reference number for the unsealed bushing is TF00-...

The Tandem Centre Flanged Ball Bushings are also available with all parts manufactured from steel (unsealed). Ordering reference number TF00-0..

If required they are available with all parts manufactured from stainless steel. Ordering reference number TF00-5..

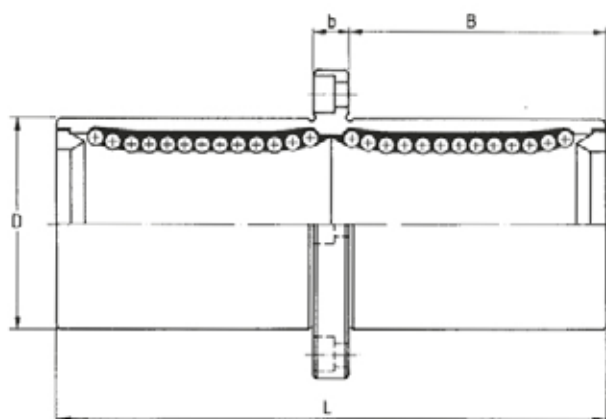
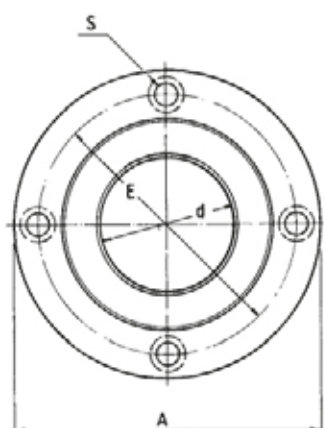

PART (No Seals)	PART (2 Seals)	d	D	L	b	B	A	E	S	Load C (N)	Load C ₀ (N)	Weight (kg)
TF00-008	TF02-308	8	16	46	5	20.5	32	24	M3	430	820	0.06
TF00-012	TF02-312	12	22	61	6	27.5	42	32	M4	830	1580	0.08
TF00-016	TF02-316	16	26	68	6	31	46	36	M4	940	1820	0.10
TF00-020	TF02-320	20	32	80	8	36	54	43	M5	1400	2800	0.26
TF00-025	TF02-325	25	40	112	8	52	62	51	M5	1600	3200	0.54
TF00-030	TF02-330	30	47	123	10	56.5	76	62	M6	2550	5600	0.82
TF00-040	TF02-340	40	62	151	13	69	98	80	M8	3500	8200	1.80
TF00-050	TF02-350	50	75	192	13	89.5	112	94	M8	6200	16200	2.80
TF00-060	TF02-360	60	90	209	18	95.5	134	112	M10	7600	20000	4.92

Tel. 01908 511733

www.euro-bearings.com

EURO-BEARINGS LTD

SQUARE MID FLANGED TANDEM BUSHES

These tandem (i.e double length) square flanged ball bushings are made to the European dimensions and have the same characteristics and loadings as our popular range of round flanged ball bushings.

The flange provides a simple but robust mounting system. The ball bushing has 2 integral shaft wiping seals & a polyamide ball retainer.

The centre flange can be bolted to the bulkhead and therefore there is no need for a housing. The double length provides greater load capacity.

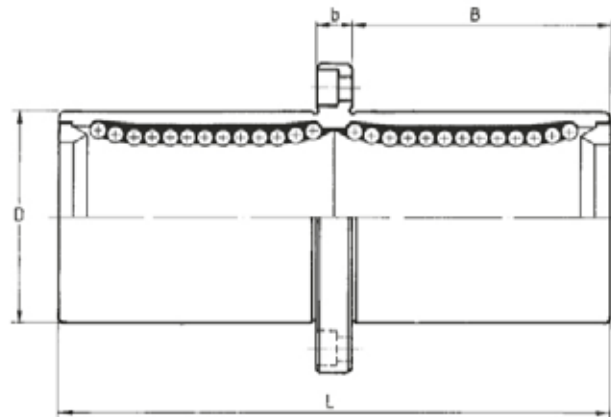
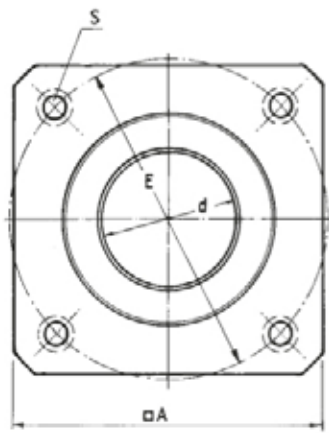

PART (2 seals)	d	D	L	b	B	A	E	S	Load C (N)	Load C ₀ (N)	Weight (kg)
LMEM08UU	8	16	46	5	20.5	25	24	M3	430	780	0.05
LMEM12UU	12	22	61	6	27.5	32	32	M4	655	1200	0.08
LMEM16UU	16	26	68	6	31	35	36	M4	1230	2350	0.16
LMEM20UU	20	32	80	8	36	42	43	M5	1400	2750	0.23
LMEM25UU	25	40	112	8	52	50	51	M5	1560	3140	0.48
LMEM30UU	30	47	123	10	56.5	60	62	M6	2490	5490	0.57
LMEM40UU	40	62	151	13	69	75	80	M8	3430	8040	1.38

TRIPLE ROUND FLANGED BALL BUSHINGS

These triple flanged ball bushings are made with a grease nipple in the middle of the two recirculating ball areas for ease of lubrication.

The flange and outer ring are made from one billet of steel thereby giving enormous strength to the design. Also due to their length they offer higher rigidity than using multiple standard ball bearings.

They are available with two seals and a plastic ball retainer as shown below (FS92-3..).

For all components in stainless steel the ordering reference is FS90-5..

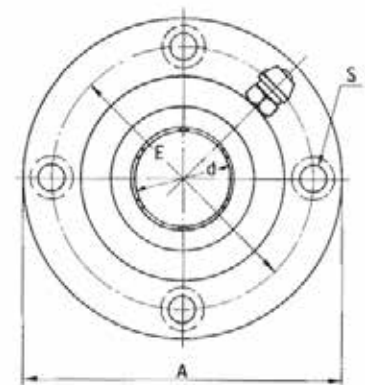
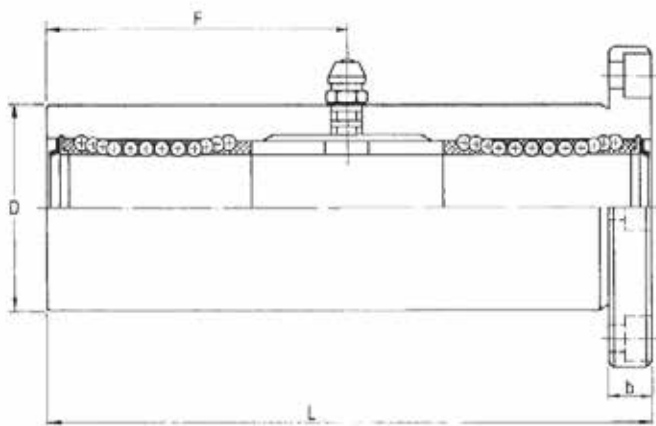

PART (2 seals)	d	D	L	b	A	E	F	S	Load C (N)	Load C ₀ (N)	Weight (kg)
FS92-308	8	19	66	6	40	29	29	M4	440	800	0.135
FS92-312	12	26	84	6	46	36	41	M4	830	1600	0.248
FS92-316	16	32	103	8	54	43	51	M5	1250	2400	0.412
FS92-320	20	40	118	8	62	51	59	M5	1430	2800	0.752
FS92-325	25	45	165	10	74	60	82.5	M6	1590	3200	1.244
FS92-330	30	52	182	10	82	67	91	M6	2540	5600	1.636
FS92-340	40	65	230	13	101	83	115	M8	3500	8200	2.950
FS92-350	50	85	290	18	129	107	145	M10	6200	16200	6.860

TRIPLE CENTRE FLANGED BUSHES

This bushing is provided with a grease nipple in the centre of the bushing for ease of lubrication. It is longer than the TF type and therefore offers higher rigidity and accuracy.

The standard type has two seals and a plastic ball retainer. Part number: TS02-3..

If required the ball bushings are available with all parts manufactured from steel (unsealed). Ordering reference number: TS00-0..

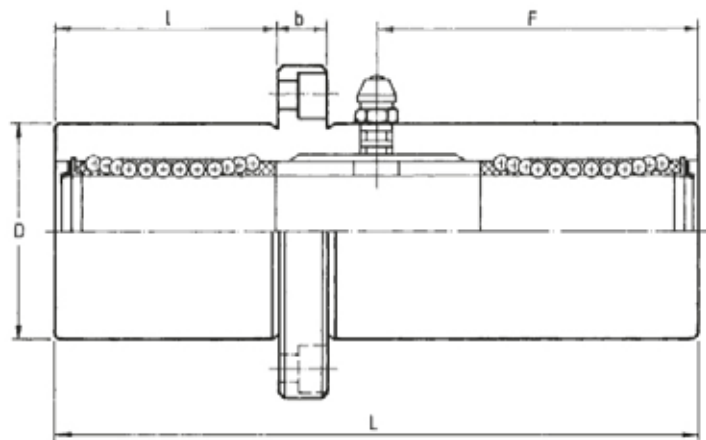
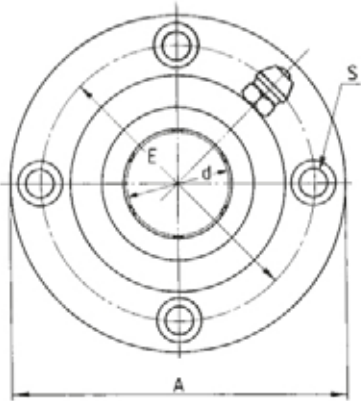

PART (2 seals)	d	D	L	b	l	A	E	F	S	Load C (N)	Load C ₀ (N)	Weight (kg)
TS02-308	8	19	66	6	22	40	29	29	M4	440	800	0.135
TS02-312	12	26	84	6	28	46	36	41	M4	830	1600	0.248
TS02-316	16	32	103	8	35	54	43	51	M5	1250	2400	0.412
TS02-320	20	40	118	8	40	62	51	59	M5	1430	2800	0.752
TS02-325	25	45	165	10	55	74	60	82.5	M6	1590	3200	1.244
TS02-330	30	52	182	10	61	82	67	91	M6	2540	5600	1.636
TS02-340	40	65	230	13	77	101	83	115	M8	3500	8200	2.950
TS02-350	50	85	290	18	97	129	107	145	M10	6200	16200	6.860

REVERSE FLANGED BALL BUSHINGS

This ball bushing is an alternative version of the flanged ball bushings. The special four-bolt flange allows a reversed mounting, in which the shorter part of the bushing is inserted into the housing bore and the longer part is protruding.



The reversed-flange ball bushings are available with two seals and a plastic ball retainer as FK22-3.. (standard length) and as FK42-3.. (tandem length).

If required the ball bushing is available unsealed - part numbers FK20-3.. and FK40-3..

They are also available with all parts manufactured from steel. Ordering reference number FK22-0.. or FK42-0..

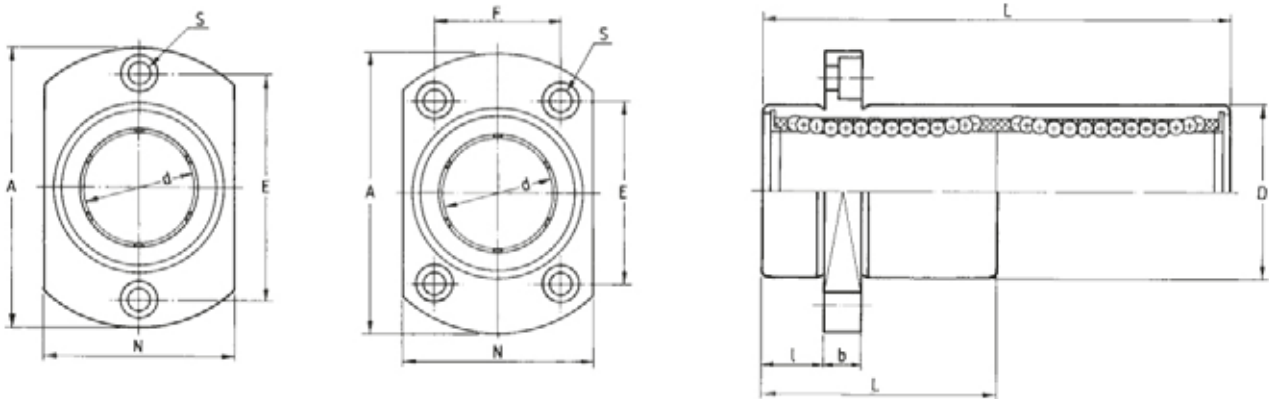

PART (2 seals)	d	D	L	b	l	A	N	E	F	S	Load C (N)	Load C ₀ (N)	Weight (kg)
FK22-306	6	12	19	5	5	28	18	20		M3	206	265	0.02
FK22-308	8	15	24	5	5	32	21	24		M3	280	400	0.03
FK22-310	10	19	29	6	6	40	25	29		M4	372	549	0.06
FK22-312	12	21	30	6	6	42	27	32		M4	520	800	0.07
FK22-316	16	28	37	6	6	48	34	31	22	M4	790	1200	0.11
FK22-320	20	32	42	8	8	54	38	36	24	M5	900	1400	0.17
FK22-325	25	40	59	8	8	62	46	40	32	M5	1000	1600	0.33
FK22-330	30	45	64	10	10	74	51	49	35	M6	1600	2800	0.39
FK22-340	40	60	80	13	13	96	96	55.1	55.1	M8	2200	4100	1.06
FK22-350	50	80	100	13	13	116	116	69.3	69.3	M8	3900	8100	2.20

PART (2 seals)	d	D	L	b	l	A	N	E	F	S	Load C (N)	Load C ₀ (N)	Weight (kg)
FK42-306	6	12	35	5	5	28	18	20		M3	323	530	0.03
FK42-308	8	15	45	5	5	32	21	24		M3	440	800	0.05
FK42-310	10	19	55	6	6	40	25	29		M4	588	1100	0.09
FK42-312	12	21	57	6	6	42	27	32		M4	830	1600	0.10
FK42-316	16	28	70	6	6	48	34	31	22	M4	1250	2400	0.18
FK42-320	20	32	80	8	8	54	38	36	24	M5	1430	2800	0.25
FK42-325	25	40	112	8	8	62	46	40	32	M5	1590	3200	0.53
FK42-330	30	45	123	10	10	74	51	49	35	M6	2540	5600	0.65
FK42-340	40	60	151	13	13	96	96	55.1	55.1	M8	3500	8200	1.57
FK42-350	50	80	192	13	13	116	116	69.3	69.3	M8	6200	16200	3.60

REVERSE ROUND FLANGED BALL BUSHES

These ball bushings are designed with a flange that allows the bush to be mounted against a bulkhead. This reverse mounting means that the shorter part of the bushing is inserted into the housing (or bulkhead) and the longer part is protruding.

The fixing holes are counterbored on the opposite side of the flange to the usual arrangement to allow for this specific type of fixing. In addition, they are easily re-lubricated via the nipple (see drawing below)



The standard type has 2 seals and a plastic cage.

Part number FK62-3..

It is also available with all parts in steel.

Part number FK60-0..

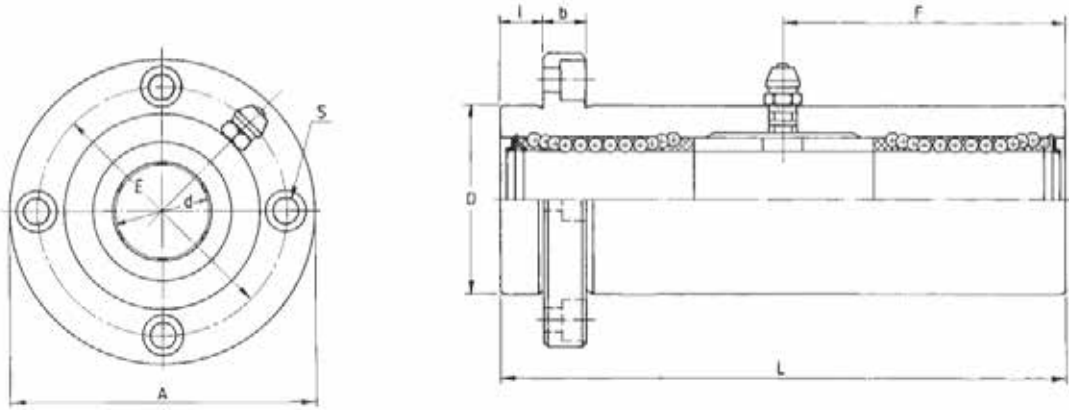

PART (2 seals)	d	D	L	b	I	A	E	F	S	Load C (N)	Load C ₀ (N)	Weight (kg)
FK62-308	8	19	66	6	6	40	29	29	M4	440	800	0.135
FK62-312	12	26	84	6	6	46	36	41	M4	830	1600	0.284
FK62-316	16	32	103	8	8	54	43	51	M5	1250	2400	0.412
FK62-320	20	40	118	8	8	62	51	59	M5	1430	2800	0.752
FK62-325	25	45	165	10	10	74	60	82.5	M6	1590	3200	1.244
FK62-330	30	52	182	10	10	82	67	91	M6	2540	5600	1.636
FK62-340	40	65	230	13	13	101	83	115	M8	3500	8200	2.950
FK62-350	50	85	290	18	18	129	107	145	M10	6200	16200	6.860

COMBINED LINEAR & RADIAL BUSHES

These rotating and sliding ball bushings allow both types of high precision motion. These motions can occur either separately or simultaneously. Given the same shaft size, the outside diameter of these ball bushings is much smaller than a combination of a standard ball bushing and a radial ball or roller bearing.

We now offer these bushes in two forms: 0662 Series with brass cage & RK series with circlip grooves in outer ring & steel cage.

0662 & RK00 do not have a flange, while RK20 has a square flange but no circlip grooves.



0662-...

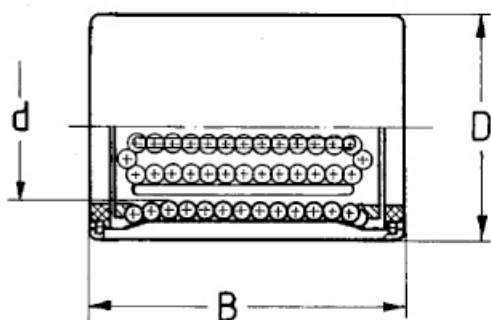

RK20-0..

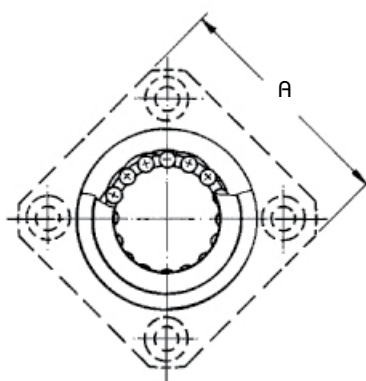

RK00-0..

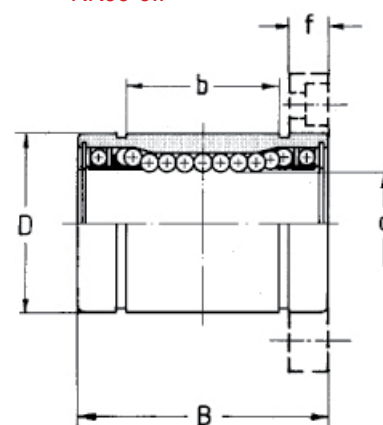

PART (Plastic seals)	PART (Steel shields)	d	D	B	b	A	f	E	S	Load C (N)	Load C ₀ (N)	Max RPM	Weight (kg)	Circlip Size
0662-006		6	10	19						46	100	1000	0.008	
	RK.0-006	6	12	19	11	22	5	20	3.5	78	176	300	0.010	12x1
0662-008		8	14	23						106	228	900	0.014	
	RK.0-008	8	15	24	15	25	5	24	3.5	137	314	300	0.015	15x1
0662-012		12	19	31						275	600	750	0.031	
	RK.0-012	12	21	30	20	32	6	32	4.5	274	588	300	0.040	21x1.2
0662-016		16	25	35						455	900	550	0.060	
	RK.0-016	16	28	37	23	37	6	38	4.5	451	882	250	0.065	28x1.5
0662-020		20	30	42						560	1220	450	0.100	
	RK.0-020	20	32	42	27	42	8	43	5.5	647	1180	250	0.110	33x1.5
0662-025		25	37	54						900	1900	350	0.200	
	RK.0-025	25	40	59	37	50	8	51	5.5	882	1860	250	0.210	42x1.75
0662-030		30	42	64						1180	2700	300	0.270	
	RK.0-030	30	45	64	40.5	58	10	60	6.6	1180	2650	200	0.290	46x1.75
0622-040		40	55	78						1930	4400	200	0.565	

TANDEM BALL BUSHINGS

These ball bushings have the same boundary dimensions as the standard ball bushings but differ in their length.

This bushing offers the advantage of using just one double-length bush in place of two standard ball bushings.

Each tandem unit has two ball recirculating 'zones' thereby virtually doubling their load capacity and their accuracy for a given shaft size.

They are available with solid end plates & all components made from steel - reference TK00-0..

Or with two seals & a plastic ball retainer - reference TK02-3..

Alternatively all parts can be made from stainless steel with stainless steel endplates. Reference TK00-5..

NB. Load capacity is for vertical loads only.

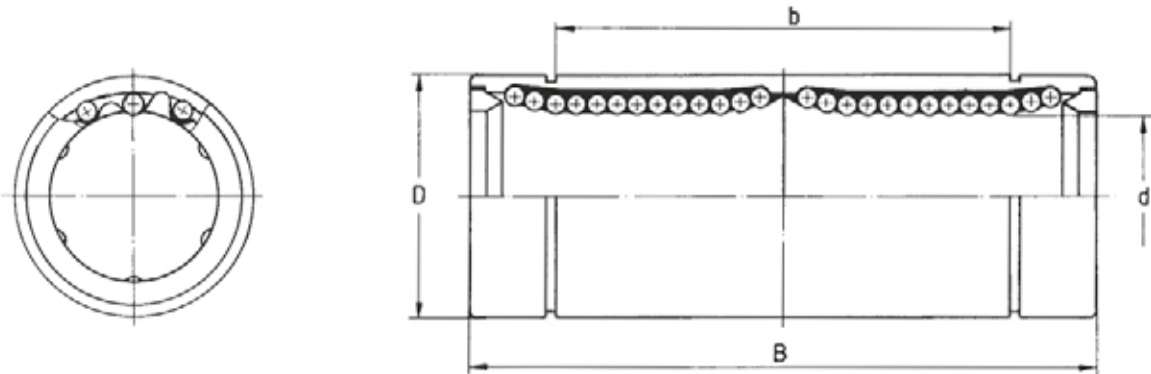

PART (no seals)	PART (2 seals)	d	D	B	b	Ball Circuits	Load C (N)	Load C ₀ (N)	Weight (kg)	Circlip Size
TK00-008	TK02-308	8	16	46	30.5	4	430	820	0.04	16x1
TK00-012	TK02-312	12	22	61	43	4	830	1580	0.08	22x1.2
TK00-016	TK02-316	16	26	68	47	4	940	1820	0.12	27x1.2
TK00-020	TK02-320	20	32	80	57.5	5	1400	2800	0.18	33x1.5
TK00-025	TK02-325	25	40	112	78	6	1600	3200	0.43	42x1.75
TK00-030	TK02-330	30	47	123	100	6	2550	5600	0.62	48x1.75
TK00-040	TK02-340	40	62	151	116.5	6	3500	8200	1.40	62x2
TK00-050	TK02-350	50	75	192	149.5	6	6200	16200	2.32	75x2.5