

DS05

Variable Area Flowmeter and Switch, mounting independent

- for low viscosity liquids
- any mounting position without recalibration
- small mounting dimensions
- brass (nickel plated) or stainless steel version
- high switching accuracy
- scales burned into the sight glass
-  optional Ex- version acc. to ATEX
- analogue transmitter 4...20 mA optional
- P_{\max} : 10 bar, T_{\max} : 160 °C



Description:

The flowmeter and switch model DS05 works according to a modified variable area principle.

The float is guided in a cylindrical measuring glass by means of a spring. The flowing medium moves the float in the flow direction. The upper edge of the float shows the momentary flow via a burnt-in scale on the measuring glass.

A Reed contact is mounted outside the meter in a sealed housing. When the float reaches the position of the Reed contact the switch will close. With higher flows the float moves further upward until it reaches a built-in float stop, still keeping the switch closed. This ensures a bistable switch function at any time.

The Reed contact is adjustable over the full switching range of the meter.

Typical application:

The variable area flowmeters and monitors DS03 are used to measure and monitor continuous flow rates of low-viscosity liquids or gaseous media.

Areas of applications are:

- cooling systems
- engineering
- medical technology
- pharmaceutical and chemical industries
- research and development

Models:

Measuring ranges: 0,2–4 l/min ... 35–250 l/min water

Materials: brass (nickel plated) and stainless steel

Technical Data:

Max. pressure: 10 bar

Pressure loss: 0,02–0,8 bar

Max. media-temperature: 100 °C (optional 160 °C)
Ex-devices acc. to. ATEX-marking

Electr. Connection: angle plug acc. to EN 155301-803, form A (DIN 43650),
Ex-contact with 2 m cable
optional: cable connection
round plug M12 x 1 acc. to EN 50044
angle plug with LED or glow lamp

Accuracy: ± 5 % of full scale
(for vertical mounting)

Materials:

**Protective housing:
(non-wetted parts)** aluminium anodized

Brass version (nickel-plated):

Wetted parts:
float: stainless steel 1,4571
spring: stainless steel 1.4571
sight glass: borosilicate glass
gaskets: NBR, optional FKM, EPDM

all other wetted parts: brass, nickel plated

Stainless steel version (1.4571):

Wetted parts:
sight glass: borosilicate glass
gaskets: FKM, optional NBR, EPDM

all other wetted parts: stainless steel 1.4571

Order Code:

Order number: DS05. 3. 1. 1. 06. 1. 1. 0

**Variable area flowmeter-
and switch**

Connection female thread:

1 = G 1/4	1N = 1/4" NPT
1A = G 3/8	1AN = 3/8" NPT
2 = G 1/2	2N = 1/2" NPT
3 = G 3/4	3N = 3/4" NPT
4 = G 1	4N = 1" NPT
5 = G 1 1/4	5N = 1 1/4" NPT

Material:

1 = brass nickel-plated
2 = stainless steel 1.4571

Scale:

1 = for water

Measuring ranges:

DS05.1, DS05.1A and DS05.2:

01 = 0,2–4 l/min (water)
02 = 0,5–6 l/min (water)
03 = 0,5–8 l/min (water)
04 = 0,5–14 l/min (water)

only DS05.2:

05A = 2–22 l/min (water)
05 = 1–28 l/min (water)

only DS05.3:

06 = 1–45 l/min (water)

DS05.3 and DS05.4:

07 = 2–80 l/min (water)
07A = 6–90 l/min (water)

only DS05.4:

08 = 6–110 l/min (water)

only DS05.5:

09 = 15–150 l/min (water)
10 = 50–220 l/min (water)
11 = 50–250 l/min (water)

Number of contacts:

0 = without contact
1 = 1 contact
2 = 2 contacts

Contact function / analogue output:

0 = without
1 = N/O
2 = SPDT
2X = SPDT for SPS application
3ST5 = Ex-N/O, T5 (100 °C), with 2 m cable
3ST6 = Ex-N/O, T6 (80 °C), with 2 m cable
3UT5 = Ex-SPDT, T5 (100 °C), with 2 m cable
3UT6 = Ex-SPDT, T6 (80 °C), with 2 m cable
SU20 = analogue transmitter 4...20 mA and 0...10 V

Options:

0 = without
1 = please specify in plain text
HT = high temperature version 160 °C
M12 = round plug M12 x 1 acc. to EN 50044 (Tmax. 85 °C)
Kx = cable version 1 m, 2 m, 5 m or 10 m

Dimensions:

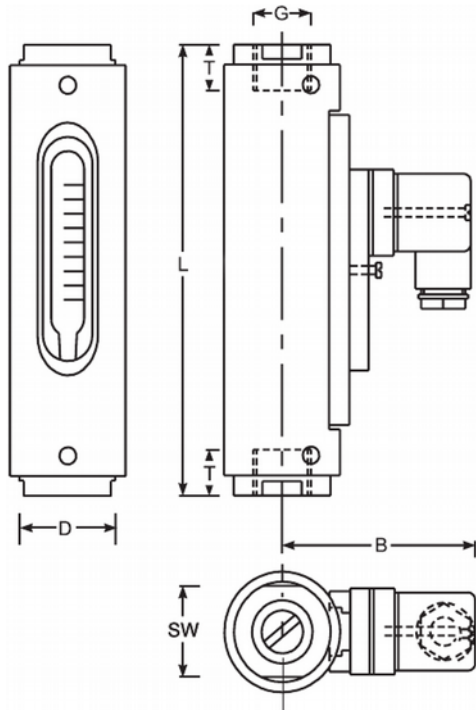

Dimensions:

Type	Dimensions [mm]						Weight appr.[g]
	SW	D	B	G	T	L	
DS05.1.x.x.x	32	43	73	G 1/4	10	132	625
DS05.1A.x.x.x	32	43	73	G 3/8	11	135	625
DS05.2.x.x.x	32	43	73	G 1/2	14	135	625
DS05.2.x.x.05	32	43	73	G 1/2	14	135	650
DS05.3.x.x.06	32	43	73	G 3/4	15	167	850
DS05.3.x.x.07	41	50	76	G 3/4	15	164	1000
DS05.4.x.x.07	41	50	76	G 1	17	184	1000
DS05.4.x.x.08	41	50	76	G 1	17	184	1000
DS05.5.x.x.09	50	55	79	G 1 1/4	20	216	1000
DS05.5.x.x.10	55	60	81	G 1 1/4	20	210	1700
DS05.5.x.x.11	50	55	79	G 1 1/4	20	222	1400

Contacts:

The contact opens/changes, if the flow level has fallen under the adjusted value

Type	Size	Contact function	Switching capacity		
			Angle plug IP65	M12x1 plug IP67	Cable connection (1 m) IP67
DS05.1	1/4"	1 = N/O	250 V / 3 A / 100 VA		
DS05.1A	3/8"	2 = SPDT	250 V / 1,5 A / 50 VA, min. Last: 3 VA		
DS05.2	1/2"	2X = SPDT for SPS	250 V / 1 A / 60 VA	-/-	-/-
DS05.3	3/4"	3ST5 = Ex-N/O, T5*	-/-	-/-	250 V / 2 A / 60 VA (2 m cable)
DS05.4	1"	3ST6 = Ex-N/O, T6*	-/-	-/-	250 V / 1 A / 30 VA, min load: 3 VA (2 m cable)
DS05.5	1 1/4"	3UT5 = Ex-SPDT, T5*	-/-	-/-	
		3UT6 = Ex-SPDT, T6*	-/-	-/-	

* Exact max. switching capacity: see ATEX documents

ATEX-designations:

Contacts 3ST5, 3ST6, 3UT5, 3UT6:

ATEX II 2 G Ex mb IIC T6 Gb, ATEX II 2 D Ex tb IIIC T80 °C Db
ATEX II 2 G Ex mb IIC T5 Gb, ATEX II 2 D Ex tb IIIC T100 °C Db
(with cable connection, Standard 2 m only)

Analogue Transmitter SU20:

The position of a magnetic float / piston is detected by means of Hall sensors and converted into an analogue signal. .

- analogue signal 4...20 mA and 0...10 V
- operating temperature: -20... +70 °C
- accuracy: +/- 10 % of full scale
- Aluminium housing, anodized



Technical Data:

Accuracy*:	+/- 1 % of full scale
Operating temperature:	-20...+70 °C
Storage temperature:	-20...+80 °C
Repeatability:	tbd.
Housing material:	Aluminium, blue anodized
Protection class:	IP67

* The actual accuracy depends on the flow sensor used. On request the accuracy of the flow sensor used can be significantly increased by a customized calibration.

Electrical Data:

Analogue output:	4...20 mA and 0...10 V
Power supply:	24 V _{CD} (19...30 V _{DC})
Power consumption:	< 1 W
Current output:	max. load 600 Ohm
Voltage output	max. current 10 mA
Connection:	round plug M12x1, 5-pole

Notes:

Flowmeter and analogue transmitter SU20 have been optimally adjusted to each other and may not be exchanged.

Electrical Connection:

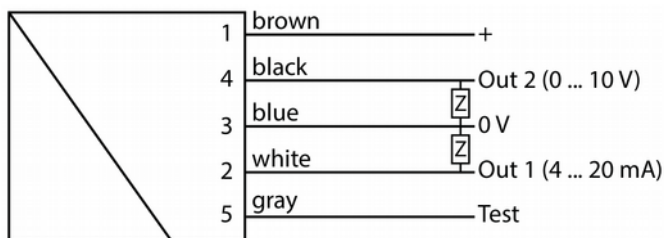

Attention: Pin 5 must not be electrically connected! We strongly recommend use of a four core cable.

Dimensions:

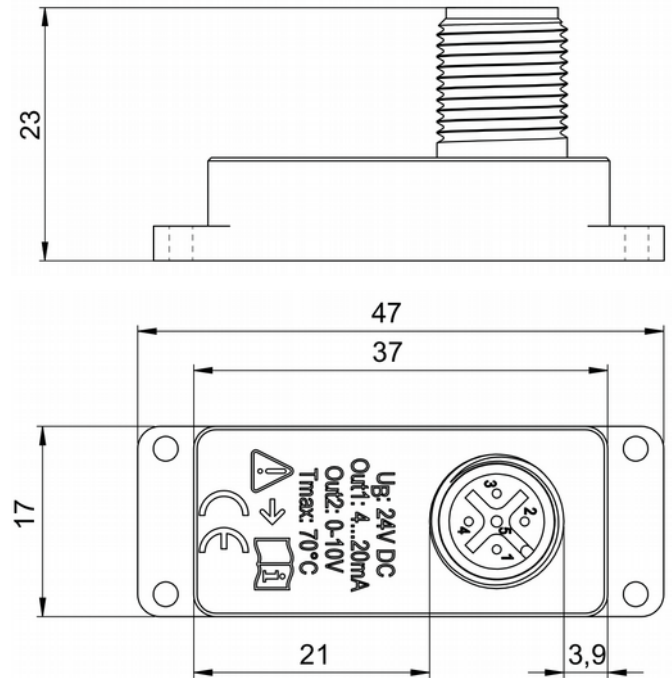

Characteristics:

Current-Flow characteristic:

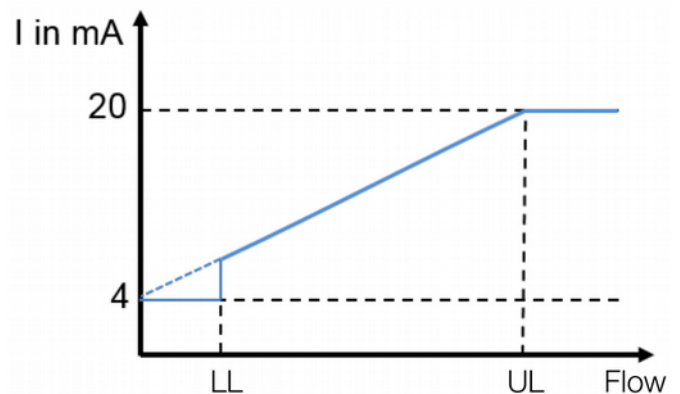

Voltage-Flow characteristic:

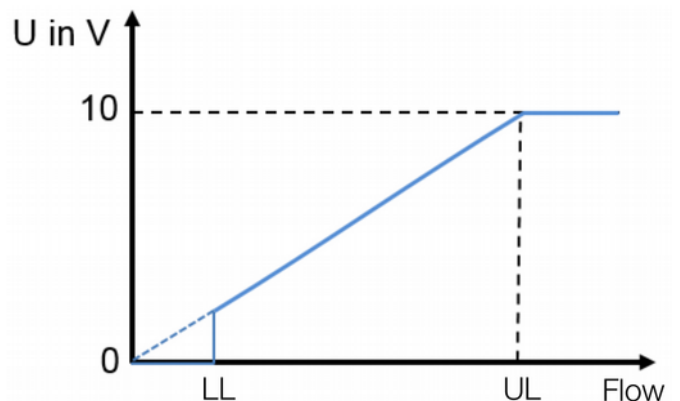

LL: lower limit of measuring range
UL: upper limit of measuring range

Accessories (see separate data sheets):

- Needle valves SNV01, SNV02



- Ball valves SKG01, SKG02



- Dirt traps SF00, SF01



- Protection relay MSR01



- M12 Plug connector PVC-cable SM12



Notes:

The specified measuring/switching ranges apply when the instrument is installed vertically and the flow rate is from bottom to top.

Other installation positions or operating densities deviating from the specified specifications increase the specified measuring error.

Special scales for different media and operating conditions are available on request.

The specified switching points are shut-off points at falling flow rates. Please note that the switch-on points are higher due to the hysteresis.

For applications where pressure surges are to be expected, please contact PKP!