

Linear modules LM

LM 12 - LM 32

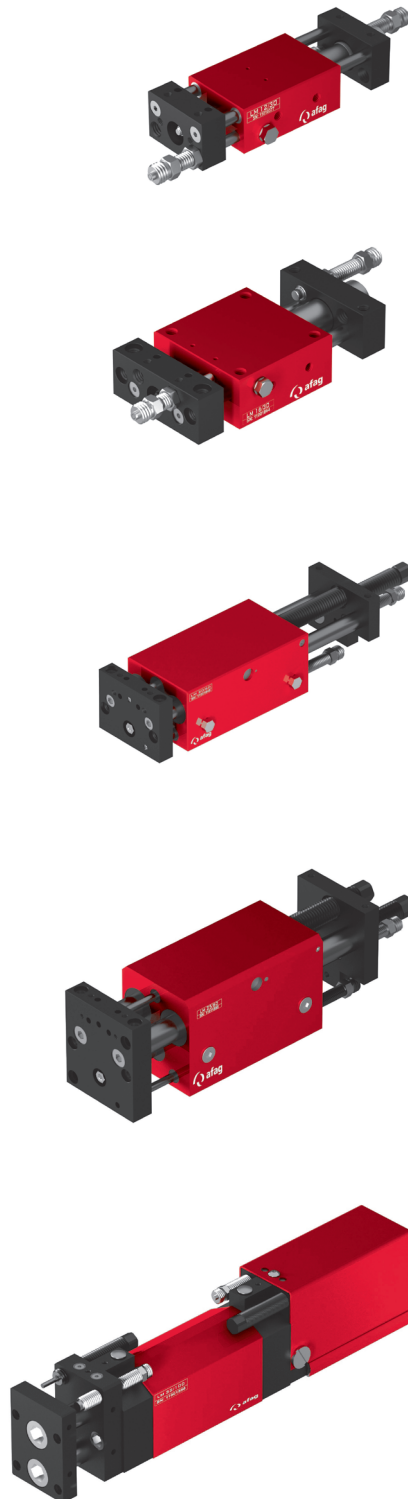
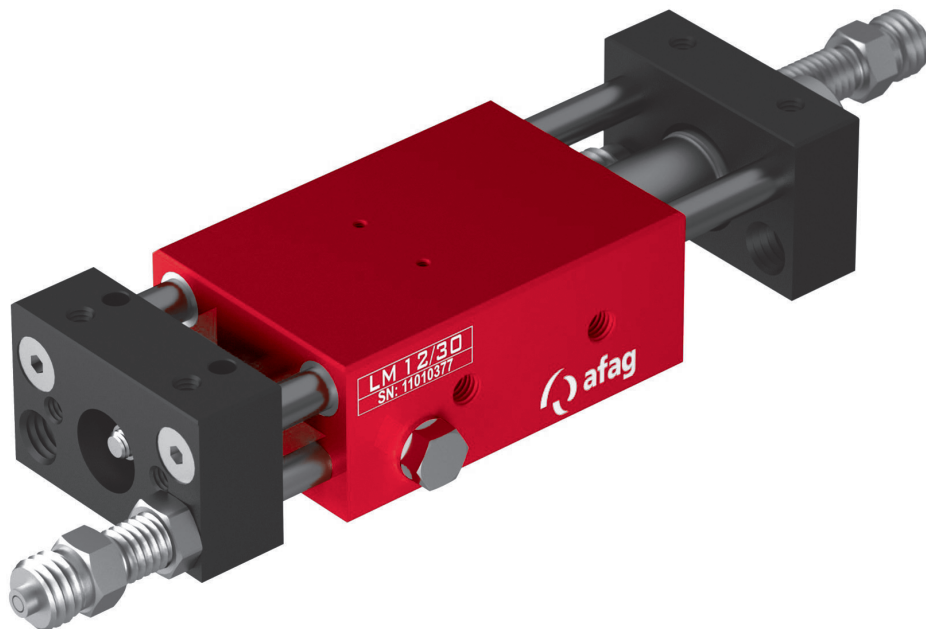

Table of contents: LM

Linear modules LM	Page
LM 12	55
LM 16	61
LM 20	67
LM 25	73
LM 32	79
Accessories LM	84

Linear modules LM

LM 12



- Super robust
- Optional intermediate stops
- Tried, tested and frequently copied

Dimensions and dimension drawings

LM 12

Type	LM 12/30	LM 12/60	LM 12/90
A	117 mm	147 mm	177 mm
B	107 mm	137 mm	167 mm
H	30 mm	60 mm	90 mm
P	M5	M5	M5

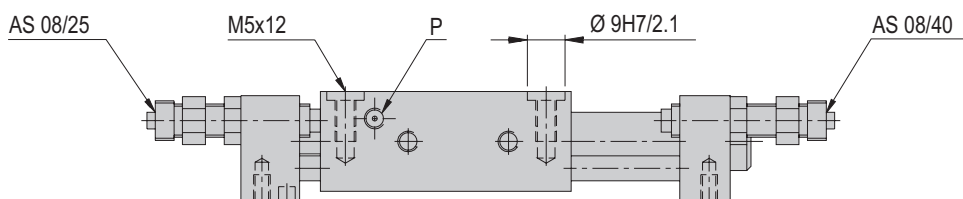
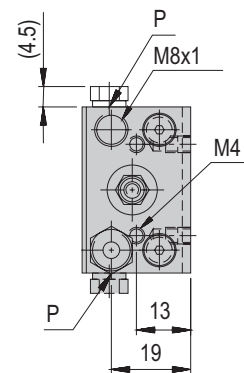
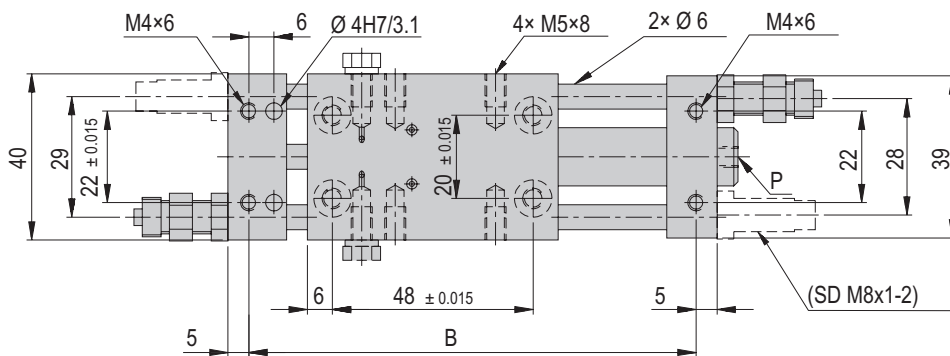
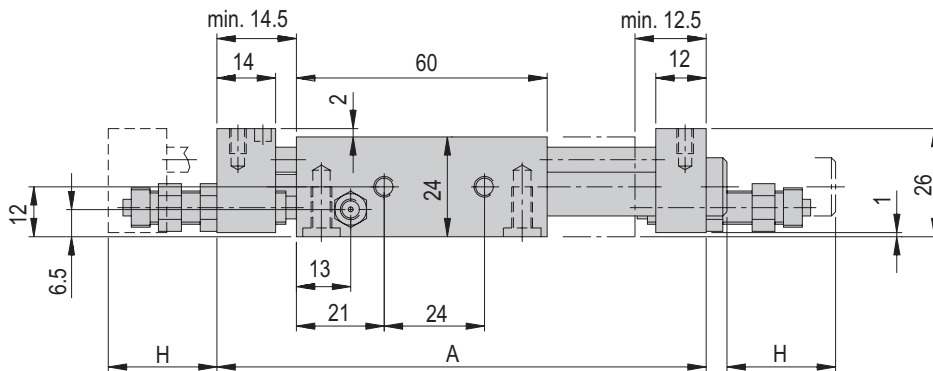

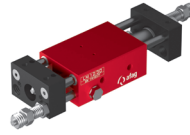

LM 12	
Attachment grid	20 x 48 mm
Attachment thread	M5
Operating pressure	6 +/- 2 bar
Air connection P	M5
Cylinder Ø	12 mm
Retract piston force	51 N
Extend piston force	68 N
Operating temperature	0 - 50 °C
Storage temperature	0 - 50 °C
Humidity	< 90 %
Medium filtered compressed air	10 - 40 µm

Type	LM 12/30	LM 12/60	LM 12/90
Order number	11010377	11010378	11010379
Stroke H	30 mm	60 mm	90 mm
Stroke limitation	*20 mm	*20 mm	*20 mm
Net weight	0.31 kg	0.34 kg	0.37 kg
Moving weight	0.13 kg	0.16 kg	0.19 kg
Air consumption/cycle	0.019 NL	0.038 NL	0.057 NL
Noise level	60 dB (A)	60 dB (A)	60 dB (A)
Repeat accuracy	+/- 0.02 mm	+/- 0.02 mm	+/- 0.02 mm
Mounting position	✦	✦	✦

The technical data refer to a nominal pressure of 6 bar under Afag standard test conditions.
 The module can be operated with lubricated or dry air.
 Cleanroom class ISO 14644-1, class ISO 7
 *Optional 2 x 20 mm

Included in the delivery

(Catalogue HT accessories)

- 2x Centering bushing Ø9x4
- 1x Stop screw AS 08/25
- 1x Stop screw AS 08/40

Accessories

- Base plate LM 12 [p. 105]
 - Stop L-bar LM 12/LM 16 [p. 105]
- (Catalogue HT accessories)
- Adjusting stop pin M8x1/40
 - Adjusting stop pin M8x1/25
 - Stop screw AS 08/80
 - Shock absorber SD M8x1 -2
 - INI d6.5x44-Sn1.5-PNP-NO-M8x1

Alternative accessories

(Catalogue HT accessories)

- INI d6.5x35-Sn1.5-PNP-NO-M8x1

Warranty: 24 months following commissioning, but a maximum of 27 months following delivery

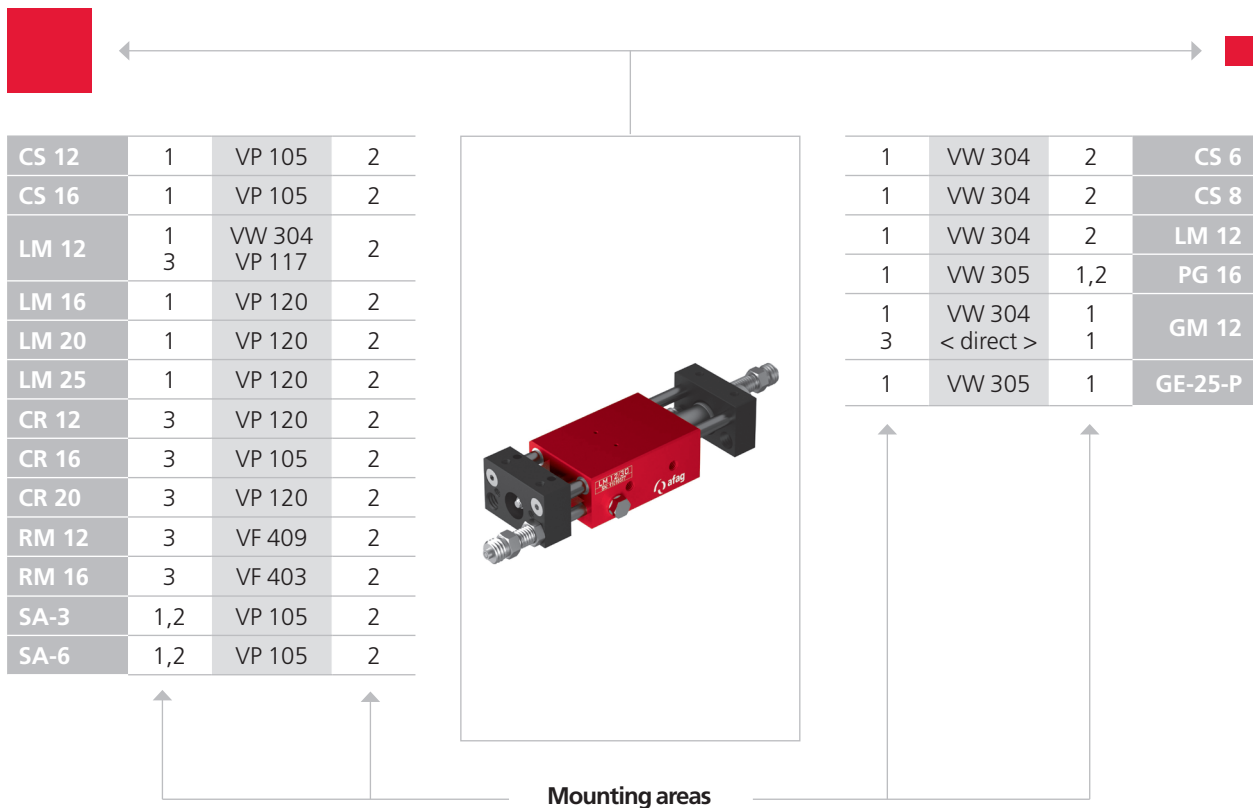

CS, ES 	LM 	HM 	SA 	UG, GM, SG, DG, PG, GE, SGE
PMP, PMP-c 	PEZ, PDZ 	PEL, PDL 	RM, RE 	CR, RM 32, RE, SREH, RA

Note that there might be different mounting positions from one module to another one.

The required connection elements and the range of support columns are depicted in the catalogue HT accessories.

Type	LM 12/30	LM 12/60	LM 12/90
Max. static torque Mx	5.6 Nm	5.6 Nm	5.6 Nm
Max. static torque My	9.6 Nm	9.6 Nm	9.6 Nm
Max. static torque Mz	9.6 Nm	9.6 Nm	9.6 Nm
Max. dynamic torque Mx	2.5 Nm	2.5 Nm	2.5 Nm
Max. dynamic torque My	4.3 Nm	4.3 Nm	4.3 Nm
Max. dynamic torque Mz	4.3 Nm	4.3 Nm	4.3 Nm
Effective distance Wx	68 mm	68 mm	68 mm

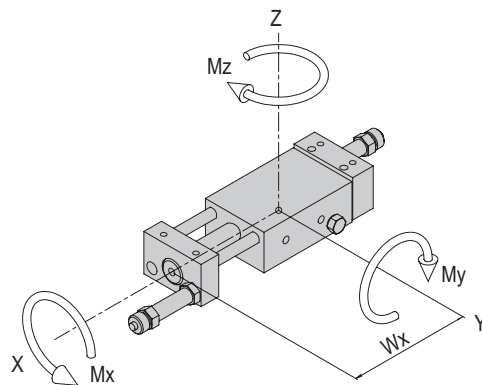

Maximum payload/type	LM 12/30	LM 12/60	LM 12/90
Installation position (horizontal) for mounting side 1	0.5 kg	0.5 kg	0.5 kg
Installation position (horizontal) for mounting side 3	0.5 kg	0.5 kg	0.5 kg
Installation position (vertical) for mounting side 1	0.5 kg	0.5 kg	0.5 kg
Installation position (vertical) for mounting side 3	0.5 kg	0.5 kg	0.5 kg

Assembly sides
module mounting

horizontal:



vertical:



Operation time diagrams

Stroke time LM 12 with shock absorber

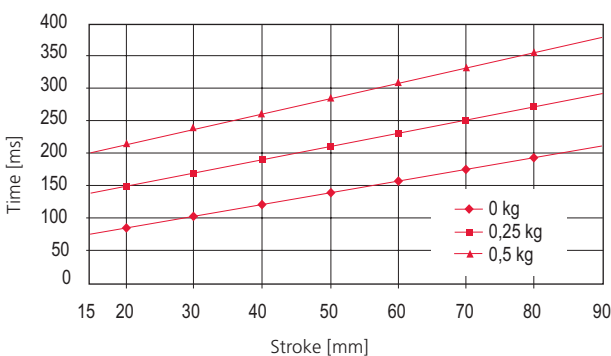

Stroke time LM 12 without shock absorber

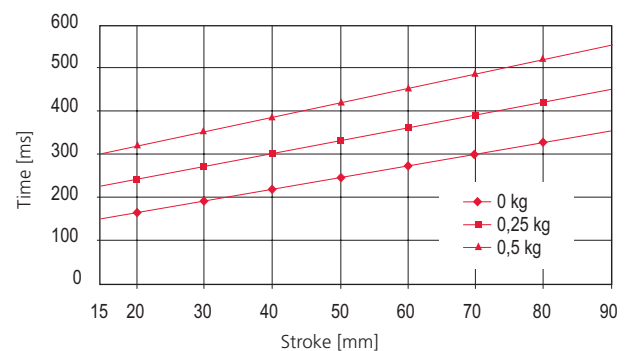

Linear modules LM

LM 16

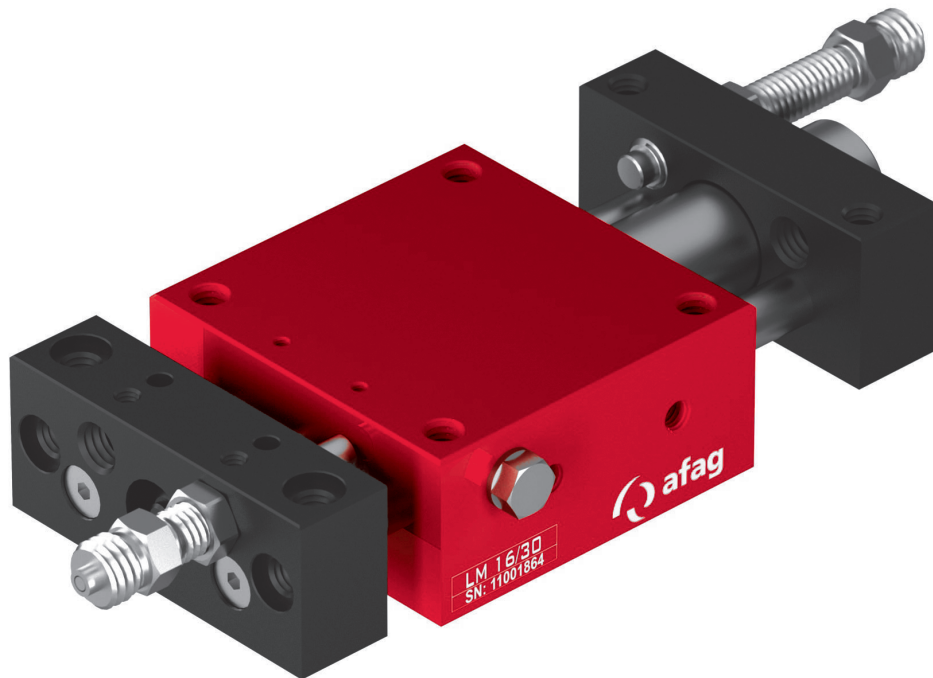

- Super robust
- Optional intermediate stops
- Tried, tested and frequently copied

Dimensions and dimension drawings

LM 16

Type	LM 16/30	LM 16/60	LM 16/90
A	122.5 mm	152.5 mm	182.5 mm
B	104.5 mm	134.5 mm	164.5 mm
H	30 mm	60 mm	90 mm
P	M5	M5	M5

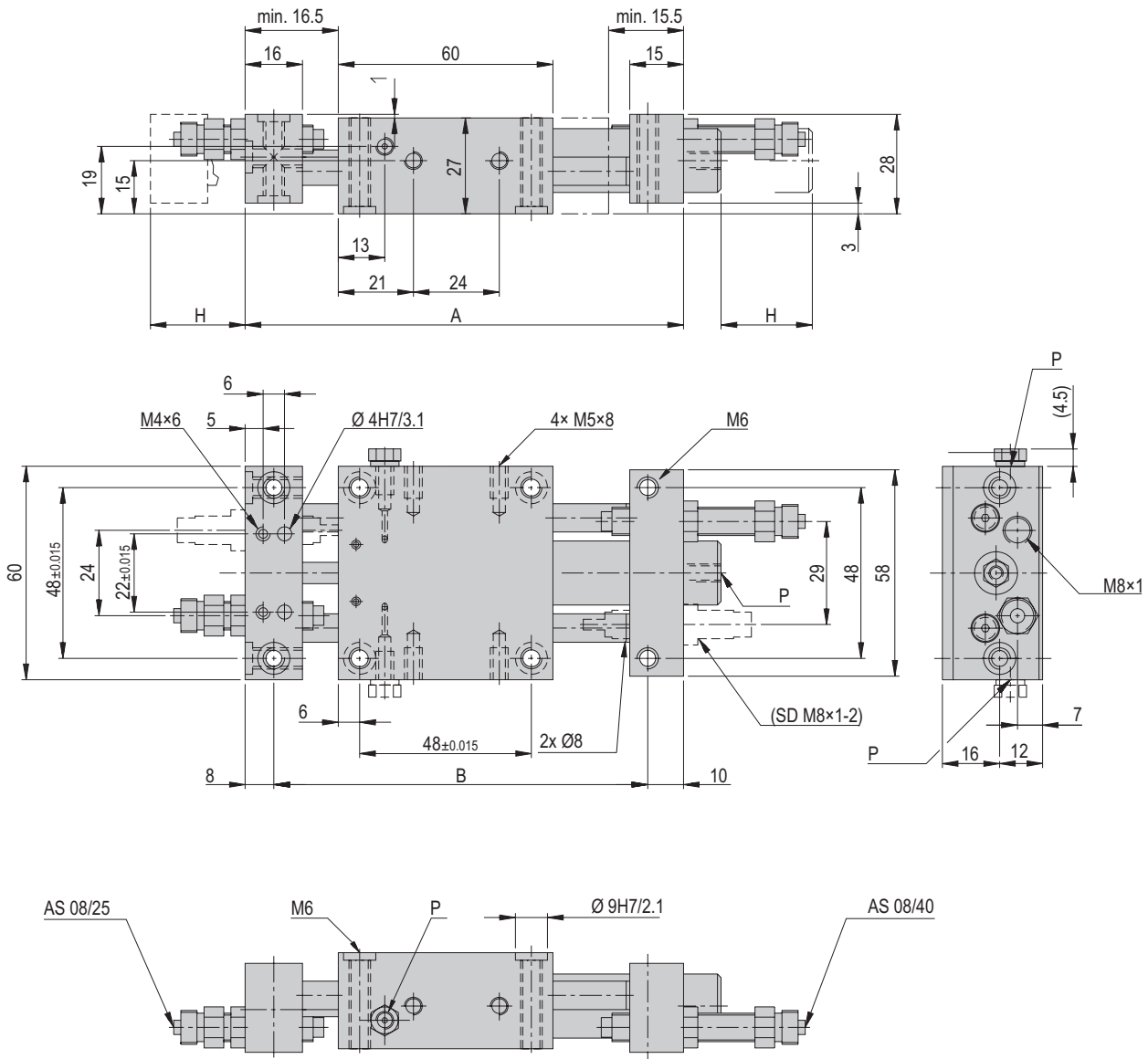

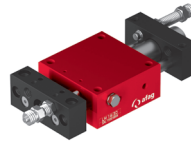

LM 16	
Attachment grid	48 x 48 mm
Attachment thread	M6
Operating pressure	6 +/- 2 bar
Air connection P	M5
Cylinder Ø	16 mm
Retract piston force	104 N
Extend piston force	121 N
Operating temperature	0 - 50 °C
Storage temperature	0 - 50 °C
Humidity	< 90 %
Medium filtered compressed air	10 - 40 µm

Type	LM 16/30	LM 16/60	LM 16/90
Order number	11001864	11001865	11001866
Stroke H	30 mm	60 mm	90 mm
Stroke limitation	*20 mm	*20 mm	*20 mm
Net weight	0.478 kg	0.515 kg	0.554 kg
Moving weight	0.138 kg	0.175 kg	0.214 kg
Air consumption/cycle	0.036 NL	0.072 NL	0.108 NL
Noise level	60 dB (A)	60 dB (A)	60 dB (A)
Repeat accuracy	+/- 0.02 mm	+/- 0.02 mm	+/- 0.02 mm
Mounting position	✦	✦	✦

The technical data refer to a nominal pressure of 6 bar under Afag standard test conditions.
 The module can be operated with lubricated or dry air.
 Cleanroom class ISO 14644-1, class ISO 7
 *Optional 2 x 20 mm

Included in the delivery

(Catalogue HT accessories)

- 2x Centering bushing Ø9x4
- 1x Stop screw AS 08/25
- 1x Stop screw AS 08/40

Accessories

- Base plate LM 16 [p. 105]
 - Stop L-bar LM 12/LM 16 [p. 105]
- (Catalogue HT accessories)
- Shock absorber SD M8x1 -2
 - Stop screw AS 08/80
 - INI d6.5x44-Sn1.5-PNP-NO-M8x1

Alternative accessories

- (Catalogue HT accessories)
- INI d6.5x35-Sn1.5-PNP-NO-M8x1

Warranty: 24 months following commissioning, but a maximum of 27 months following delivery

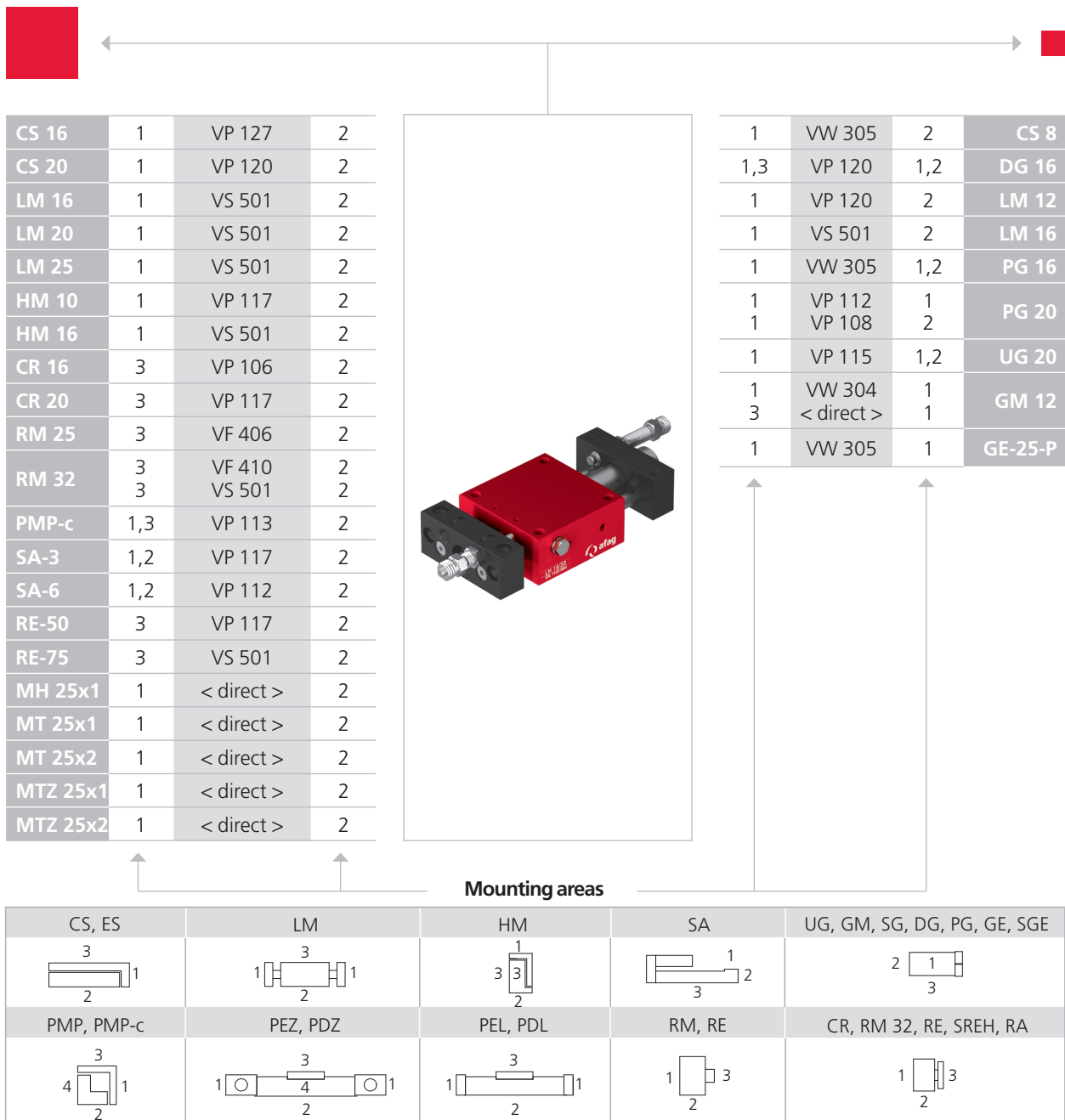

Note that there might be different mounting positions from one module to another one.

The required connection elements and the range of support columns are depicted in the catalogue HT accessories.

Type	LM 16/30	LM 16/60	LM 16/90
Max. static torque Mx	11 Nm	11 Nm	11 Nm
Max. static torque My	18 Nm	18 Nm	18 Nm
Max. static torque Mz	18 Nm	18 Nm	18 Nm
Max. dynamic torque Mx	5 Nm	5 Nm	5 Nm
Max. dynamic torque My	8 Nm	8 Nm	8 Nm
Max. dynamic torque Mz	8 Nm	8 Nm	8 Nm
Effective distance Wx	71 mm	71 mm	71 mm

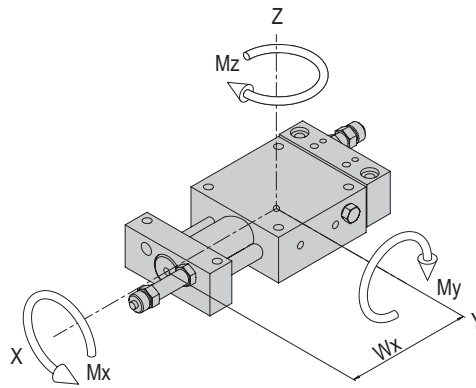

Maximum payload/type	LM 16/30	LM 16/60	LM 16/90
Installation position (horizontal) for mounting side 1	1 kg	1 kg	0.8 kg
Installation position (horizontal) for mounting side 3	1 kg	1 kg	0.8 kg
Installation position (vertical) for mounting side 1	1 kg	1 kg	0.8 kg
Installation position (vertical) for mounting side 3	1 kg	1 kg	0.8 kg

Assembly sides
module mounting

horizontal:

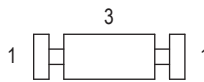

vertical:



Operation time diagrams

Stroke time LM 16 with shock absorber

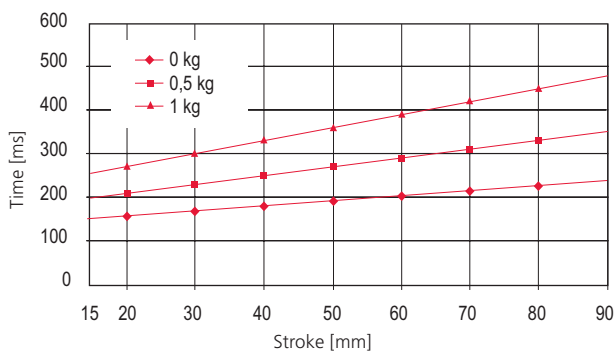

Stroke time LM 16 without shock absorber

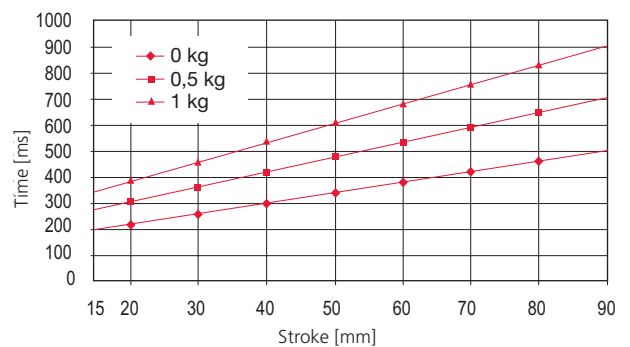

Linear modules LM

LM 20

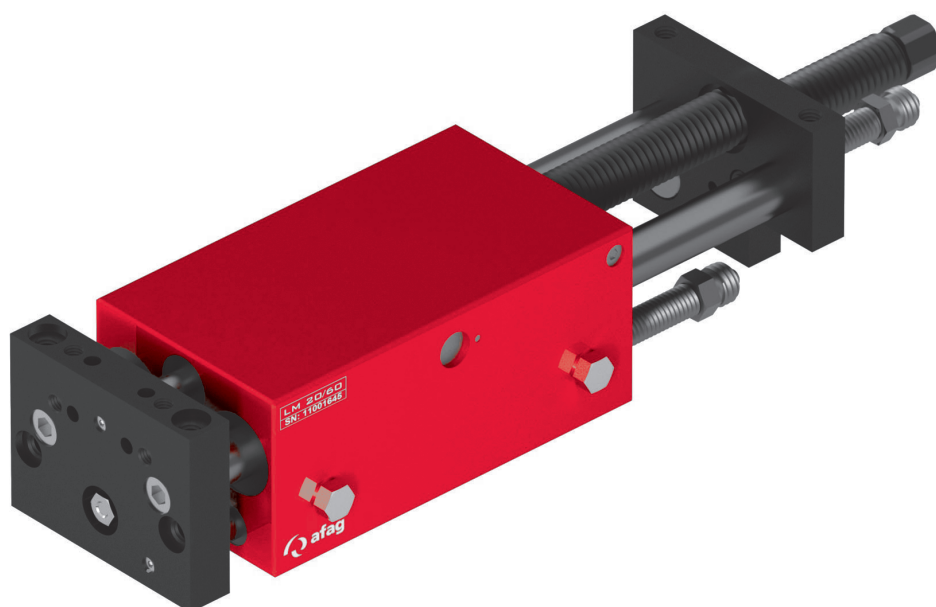

- Super robust
- Optional intermediate stops
- Tried, tested and frequently copied

Dimensions and dimension drawings

LM 20

Type	LM 20/30	LM 20/60	LM 20/90	LM 20/120	LM 20/150	LM 20/200
A	140 mm	200 mm	260 mm	320 mm	380 mm	480 mm
B	129 mm	189 mm	249 mm	309 mm	369 mm	469 mm
C	50 mm	79 mm	109 mm	139 mm	169 mm	219 mm
D	80 mm	110 mm	140 mm	170 mm	200 mm	250 mm
E	1	1	2	2	3	4
F	212 mm	272 mm	332 mm	392 mm	452 mm	552 mm
G			10 mm	24 mm		
H	30 mm	60 mm	90 mm	120 mm	150 mm	200 mm
P	M5	M5	M5	M5	M5	M5

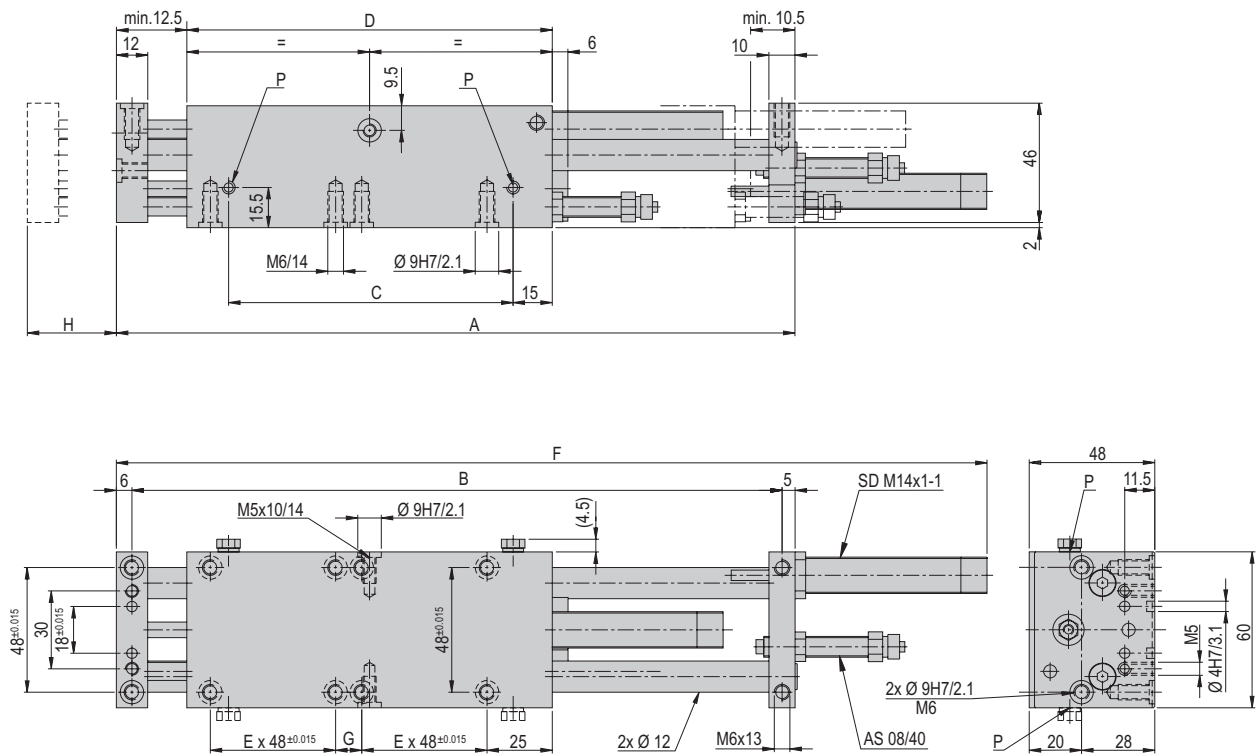

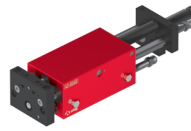

LM 20	
Attachment grid	48 x 48 mm
Attachment thread	M6
Operating pressure	6 +/- 2 bar
Air connection P	M5
Cylinder Ø	20 mm
Retract piston force	140 N
Extend piston force	172 N
Operating temperature	0 - 50 °C
Storage temperature	0 - 50 °C
Humidity	< 90 %
Medium filtered compressed air	10 - 40 µm

Type	LM 20/30	LM 20/60	LM 20/90	LM 20/120	LM 20/150	LM 20/200
Order number	11001720	11001645	11001646	11001647	11001648	11009043
Stroke H	30 mm	60 mm	90 mm	120 mm	150 mm	200 mm
Stroke limitation	2 x 25 mm	2 x 25 mm	2 x 25 mm	2 x 25 mm	2 x 25 mm	2 x 25 mm
Net weight	1.28 kg	1.55 kg	1.82 kg	2.1 kg	2.372 kg	2.82 kg
Moving weight	0.71 kg	0.84 kg	0.97 kg	1.11 kg	1.23 kg	1.44 kg
Air consumption/cycle	0.065 NL	0.125 NL	0.19 NL	0.255 NL	0.32 NL	0.43 NL
Noise level	65 dB (A)	65 dB (A)	65 dB (A)	65 dB (A)	65 dB (A)	65 dB (A)
Repeat accuracy	+/- 0.01 mm	+/- 0.01 mm	+/- 0.01 mm	+/- 0.02 mm	+/- 0.02 mm	+/- 0.02 mm
Number of interim attachments		1	1	1	1	1
Damping travel	15 mm	15 mm	15 mm	15 mm	15 mm	15 mm
Mounting position	✦	✦	✦	✦	✦	✦

The technical data refer to a nominal pressure of 6 bar under Afag standard test conditions.
 The module can be operated with lubricated or dry air.
 Cleanroom class ISO 14644-1, class ISO 7

Included in the delivery (Catalogue HT accessories)

- 2x Centering bushing Ø9x4
- 2x Stop screw AS 08/40
- 2x Shock absorber SD M14x1 -1

Accessories

- Base plate LM 20/LM 25 [p. 106]
 - 3. Position LM 20 [p. 106]
 - Intermediate stop ZA 20/25 [p. 108]
- (Catalogue HT accessories)
- Stop screw AS 08/80
 - Stop screw AS 08/25
 - INI d6.5x44-Sn1.5-PNP-NO-M8x1

Alternative accessories

- (Catalogue HT accessories)
- INI d6.5x35-Sn1.5-PNP-NO-M8x1

Warranty: 24 months following commissioning, but a maximum of 27 months following delivery

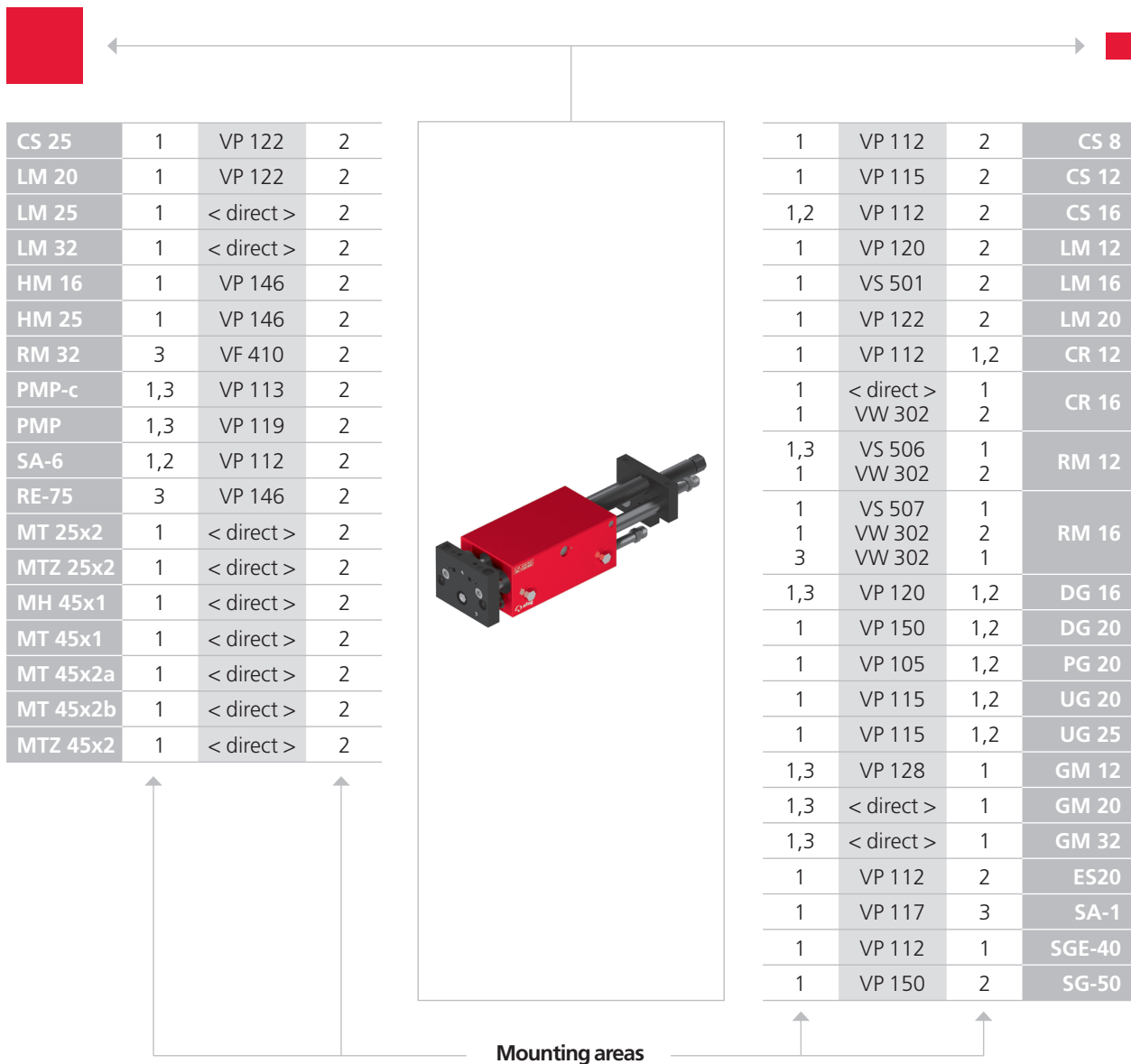

CS, ES 	LM 	HM 	SA 	UG, GM, SG, DG, PG, GE, SGE
PMP, PMP-c 	PEZ, PDZ 	PEL, PDL 	RM, RE 	CR, RM 32, RE, SREH, RA

Note that there might be different mounting positions from one module to another one.
The required connection elements and the range of support columns are depicted in the catalogue HT accessories.

Type	LM 20/30	LM 20/60	LM 20/90	LM 20/120	LM 20/150	LM 20/200
Max. static torque Mx	11 Nm	11 Nm	11 Nm	11 Nm	11 Nm	11 Nm
Max. static torque My	11 Nm	17 Nm	23 Nm	29 Nm	35 Nm	45 Nm
Max. static torque Mz	11 Nm	17 Nm	23 Nm	29 Nm	35 Nm	45 Nm
Max. dynamic torque Mx	3 Nm	3 Nm	3 Nm	3 Nm	3 Nm	3 Nm
Max. dynamic torque My	5 Nm	8 Nm	10 Nm	13 Nm	16 Nm	20 Nm
Max. dynamic torque Mz	5 Nm	8 Nm	10 Nm	13 Nm	16 Nm	20 Nm
Effective distance Wx	80 mm	110 mm	140 mm	170 mm	200 mm	250 mm

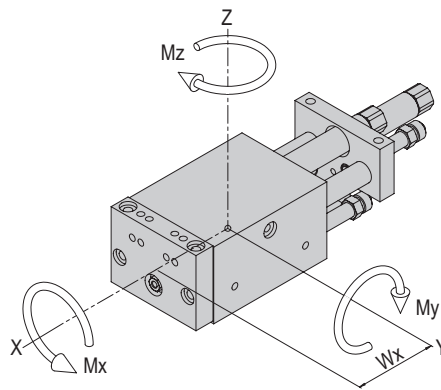

Maximum payload/type	LM 20/30	LM 20/60	LM 20/90	LM 20/120	LM 20/150	LM 20/200
Installation position (horizontal) for mounting side 1	8 kg	7 kg	5 kg	4 kg	3 kg	2 kg
Installation position (horizontal) for mounting side 3	8 kg	7 kg	5 kg	4 kg	3 kg	2 kg
Installation position (vertical) for mounting side 1	8 kg	7 kg	5 kg	4 kg	3 kg	2 kg
Installation position (vertical) for mounting side 3	8 kg	7 kg	5 kg	4 kg	3 kg	2 kg

Assembly sides
module mounting

horizontal:

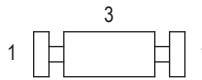

vertical:



Operation time diagrams

Stroke time LM 20 with shock absorber

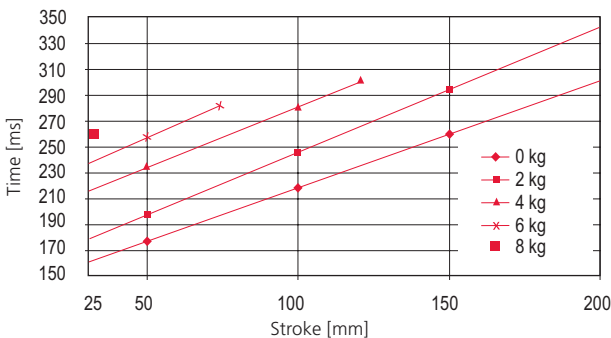

Linear modules LM

LM 25

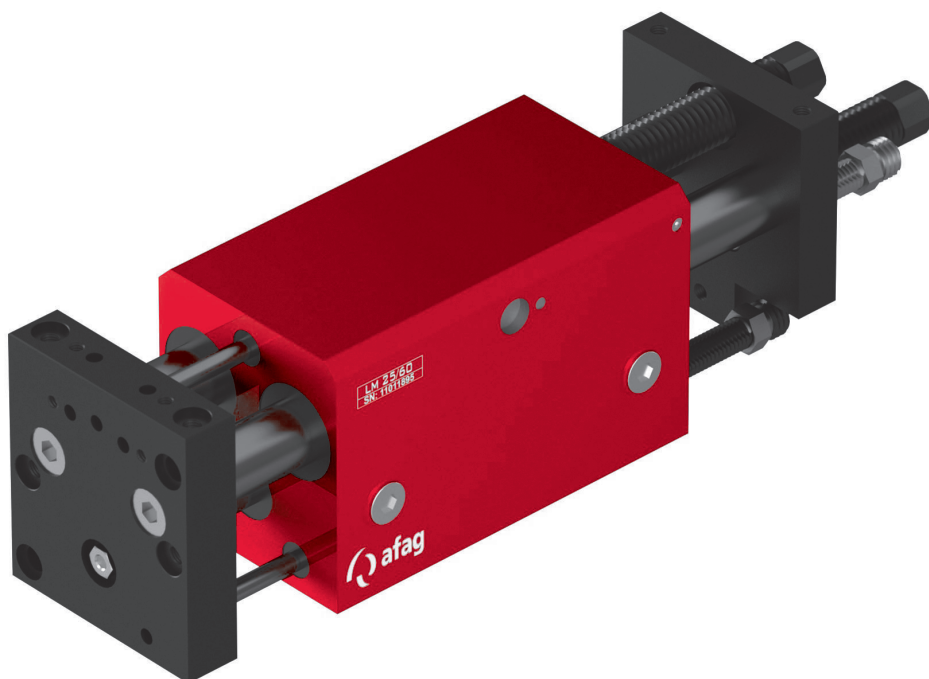

- Super robust
- Optional intermediate stops
- Tried, tested and frequently copied

Dimensions and dimension drawings

LM 25

Type	LM 25/60	LM 25/120	LM 25/200
A	202.5 mm	322.5 mm	482.5 mm
B	189 mm	309 mm	469 mm
C	80 mm	140 mm	220 mm
D	110 mm	170 mm	250 mm
E	1	2	4
F	277.5 mm	397.5 mm	557.5 mm
H	60 mm	120 mm	200 mm
P	G 1/8 "	G 1/8 "	G 1/8 "

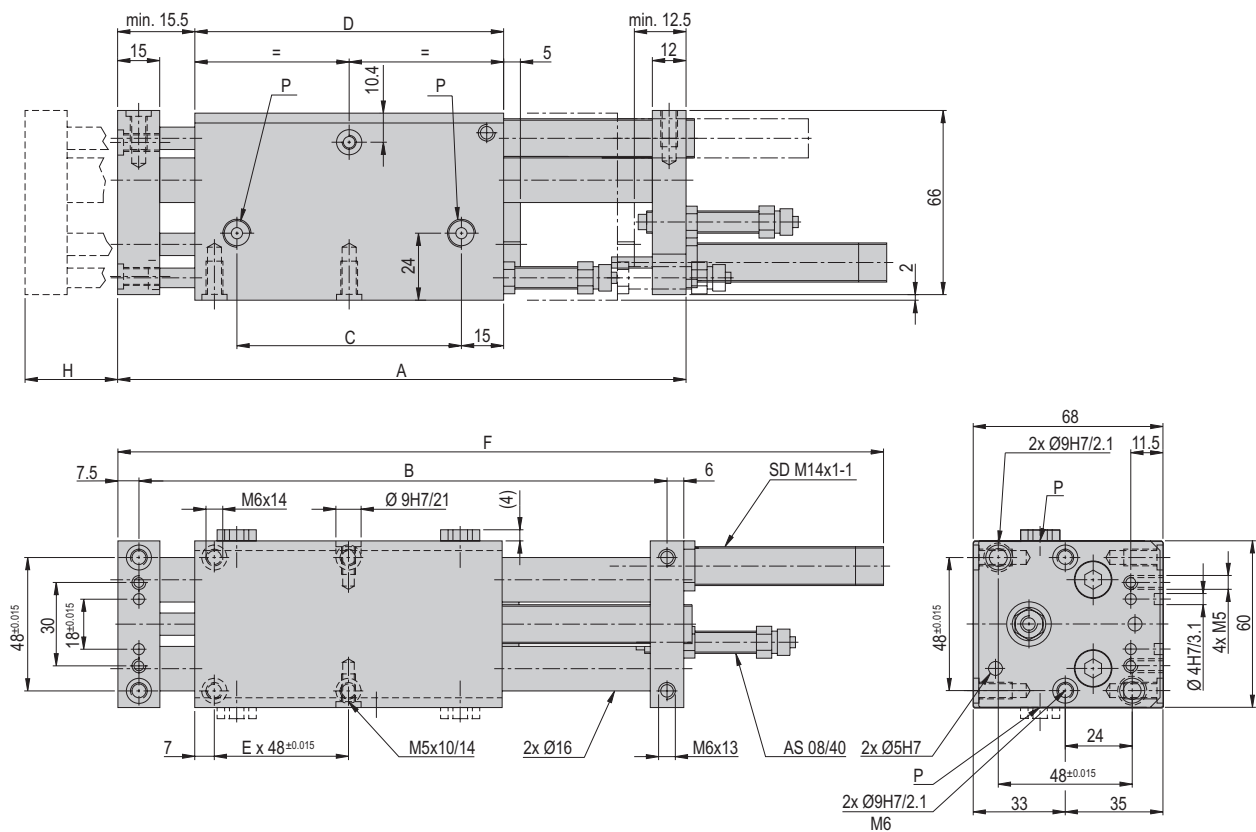



LM 25	
Attachment grid	48 x 48 mm
Attachment thread	M6
Operating pressure	6 +/- 2 bar
Air connection P	G1/8 "
Cylinder Ø	25 mm
Retract piston force	265 N
Extend piston force	295 N
Operating temperature	0 - 50 °C
Storage temperature	0 - 50 °C
Humidity	< 90 %
Medium filtered compressed air	10 - 40 µm

Type	LM 25/60	LM 25/120	LM 25/200
Order number	11011895	11011896	11011897
Stroke H	60 mm	120 mm	200 mm
Stroke limitation	2x25 mm	2x25 mm	2x25 mm
Net weight	1.965 kg	2.821 kg	3.944 kg
Moving weight	0.99 kg	1.43 kg	2.01 kg
Air consumption/cycle	0.164 NL	0.33 NL	0.55 NL
Noise level	65 dB (A)	65 dB (A)	65 dB (A)
Repeat accuracy	+/- 0.01 mm	+/- 0.02 mm	+/- 0.02 mm
Mounting position	✦	✦	✦

The technical data refer to a nominal pressure of 6 bar under Afag standard test conditions.
 The module can be operated with lubricated or dry air.
 Cleanroom class ISO 14644-1, class ISO 7

Included in the delivery

(Catalogue HT accessories)

- 2x Centering bushing Ø9x4
- 2x Stop screw AS 08/40
- 2x Shock absorber SD M14x1 -1

Accessories

- Base plate LM 20/LM 25 [p. 106]
 - 3. Position LM 25 [p. 107]
 - Intermediate stop ZA 20/25 [p. 108]
- (Catalogue HT accessories)
- INI d6.5x44-Sn1.5-PNP-NO-M8x1

Alternative accessories

- (Catalogue HT accessories)
- INI d6.5x35-Sn1.5-PNP-NO-M8x1

Warranty: 24 months following commissioning, but a maximum of 27 months following delivery

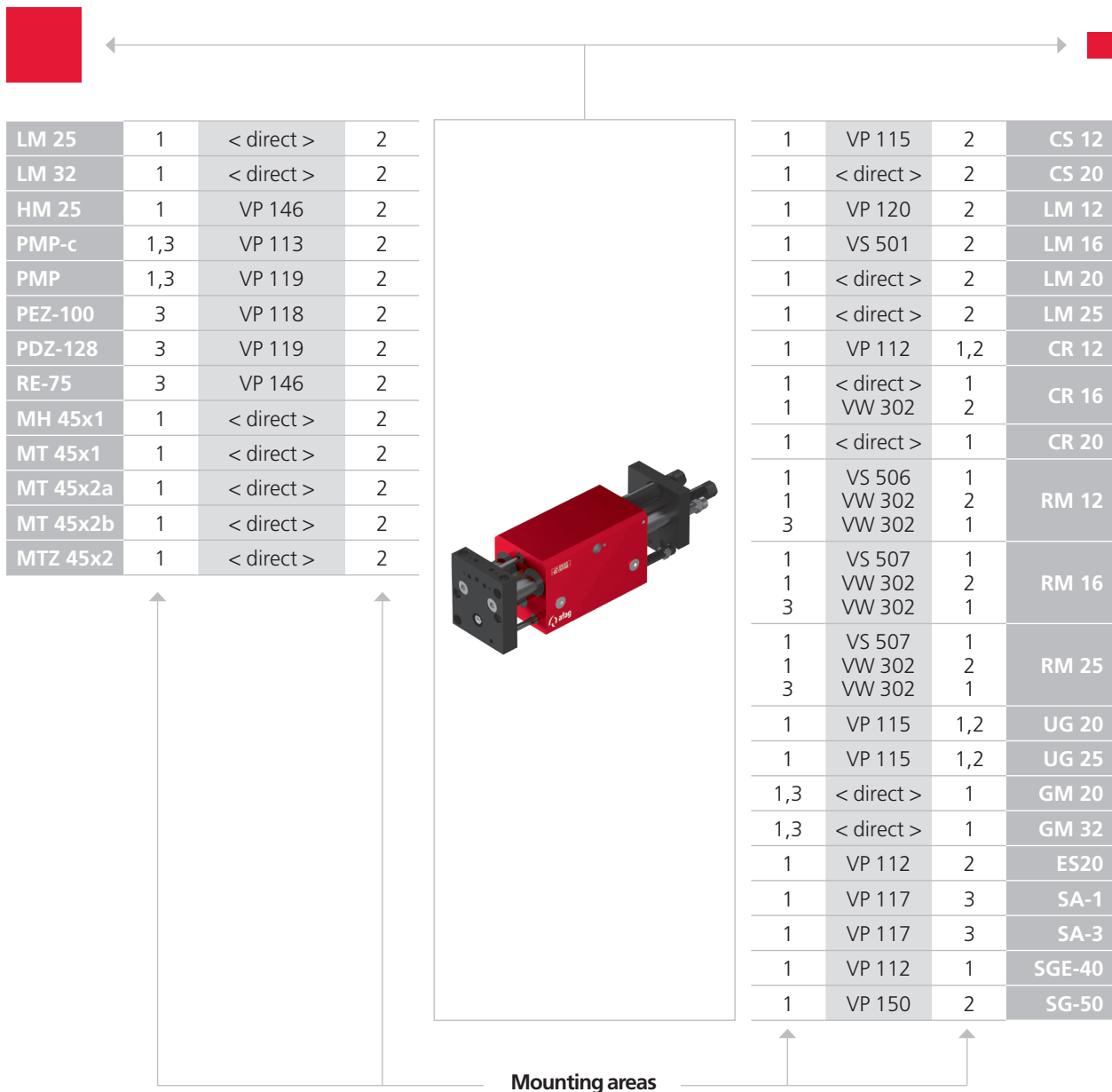

CS, ES 	LM 	HM 	SA 	UG, GM, SG, DG, PG, GE, SGE
PMP, PMP-c 	PEZ, PDZ 	PEL, PDL 	RM, RE 	CR, RM 32, RE, SREH, RA

Note that there might be different mounting positions from one module to another one.
The required connection elements and the range of support columns are depicted in the catalogue HT accessories.

Type	LM 25/60	LM 25/120	LM 25/200
Max. static torque Mx	8 Nm	8 Nm	8 Nm
Max. static torque My	20 Nm	35 Nm	55 Nm
Max. static torque Mz	20 Nm	35 Nm	55 Nm
Max. dynamic torque Mx	4 Nm	4 Nm	4 Nm
Max. dynamic torque My	9 Nm	16 Nm	25 Nm
Max. dynamic torque Mz	9 Nm	16 Nm	25 Nm
Effective distance Wx	85 mm	115 mm	145 mm

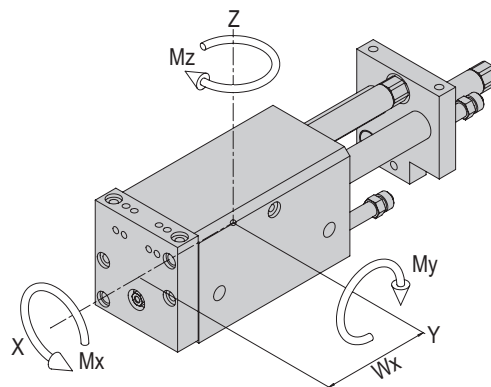

Maximum payload/type	LM 25/60	LM 25/120	LM 25/200
Installation position (horizontal) for mounting side 1	9 kg	6 kg	4 kg
Installation position (horizontal) for mounting side 3	9 kg	6 kg	4 kg
Installation position (vertical) for mounting side 1	9 kg	6 kg	4 kg
Installation position (vertical) for mounting side 3	9 kg	6 kg	4 kg

Assembly sides
module mounting

horizontal:



vertical:



Operation time diagrams

Stroke time LM 25 with shock absorber

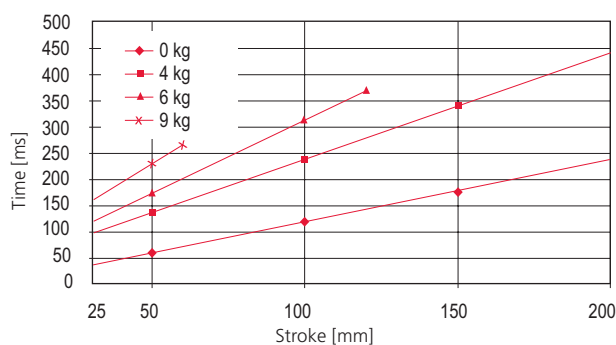

Linear modules LM

LM 32

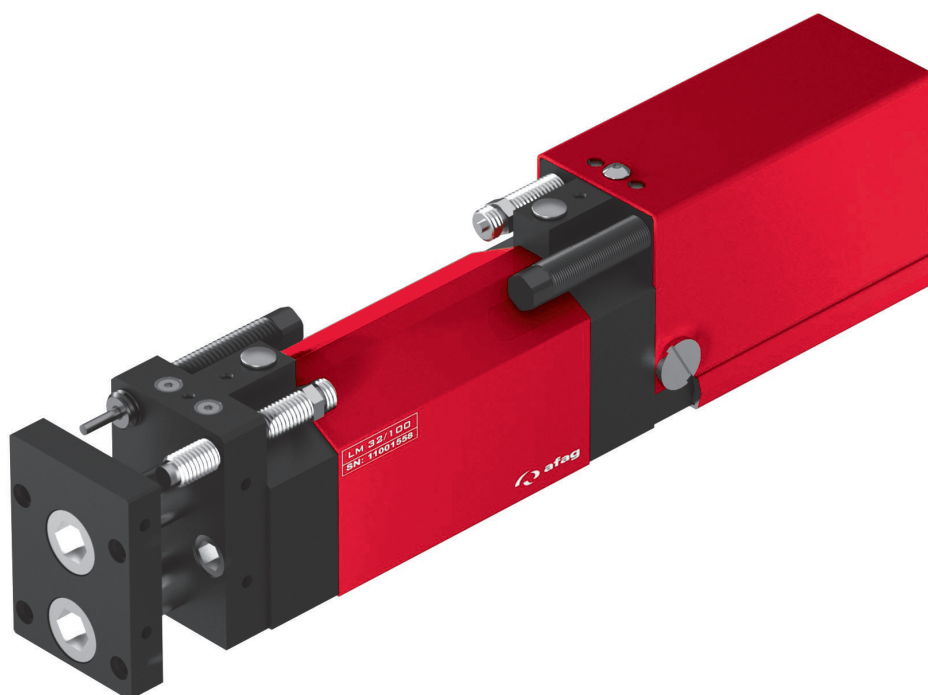

- Super robust
- Optional intermediate stops
- Tried, tested and frequently copied

Dimensions and dimension drawings

LM 32

Type	LM 32/100	LM 32/200	LM 32/300	LM 32/400
A	360 mm	560 mm	760 mm	960 mm
B	226 mm	326 mm	426 mm	526 mm
D	140 mm	240 mm	340 mm	440 mm
E	2	4	6	8
F	365 mm	565 mm	765 mm	965 mm
H	100 mm	200 mm	300 mm	400 mm
P	G 1/8 "	G 1/8 "	G 1/8 "	G 1/8 "

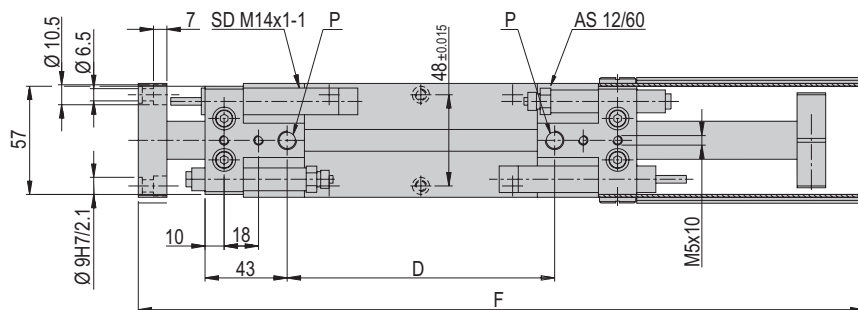
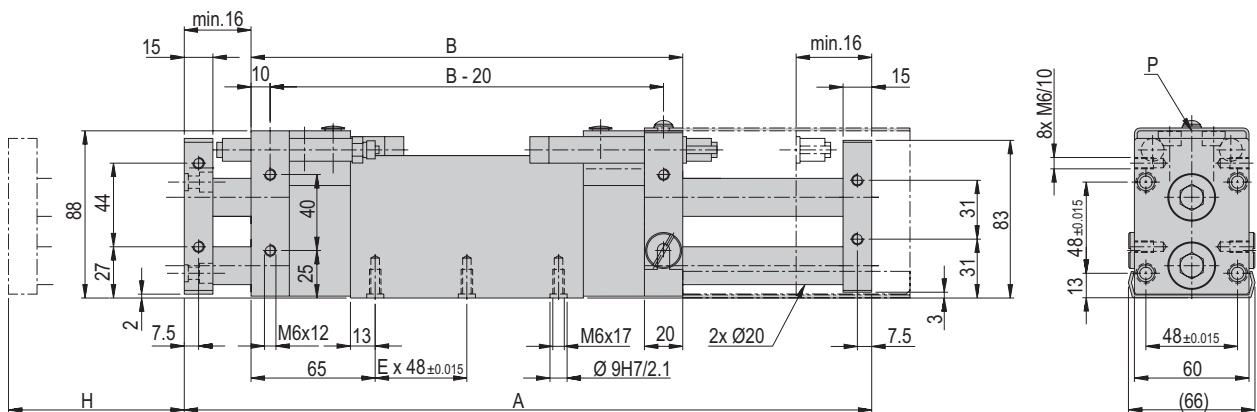



LM 32	
Attachment grid	48 x 48 mm
Attachment thread	M6
Operating pressure	6 +/- 2 bar
Air connection P	G1/8 "
Cylinder Ø	32 mm
Retract piston force	295 N
Extend piston force	295 N
Operating temperature	0 - 50 °C
Storage temperature	0 - 50 °C
Humidity	< 90 %
Medium filtered compressed air	10 - 40 µm

Type	LM 32/100	LM 32/200	LM 32/300	LM 32/400
Order number	11001558	11001559	11001561	11001562
Stroke H	100 mm	200 mm	300 mm	400 mm
Stroke limitation	2 x 40 mm	2 x 40 mm	2 x 40 mm	2 x 40 mm
Net weight	4 kg	5.4 kg	6.6 kg	7.9 kg
Moving weight	1.81 kg	2.29 kg	2.79 kg	3.28 kg
Air consumption/cycle	0.4 NL	0.8 NL	1.2 NL	1.6 NL
Noise level	65 dB (A)	65 dB (A)	65 dB (A)	65 dB (A)
Repeat accuracy	+/- 0.01 mm	+/- 0.01 mm	+/- 0.02 mm	+/- 0.02 mm
Mounting position	✦	✦	✦	✦

The technical data refer to a nominal pressure of 6 bar under Afag standard test conditions.
 The module can be operated with lubricated or dry air.
 Cleanroom class ISO 14644-1, class ISO 7

Included in the delivery

(Catalogue HT accessories)

- 2x Centering bushing Ø9x4
- 2x Stop screw AS 12/60
- 2x Shock absorber SD M14x1 -1

Accessories

(Catalogue HT accessories)

- INI d6.5x44-Sn1.5-PNP-NO-M8x1

Alternative accessories

(Catalogue HT accessories)

- INI d6.5x35-Sn1.5-PNP-NO-M8x1

Warranty: 24 months following commissioning, but a maximum of 27 months following delivery

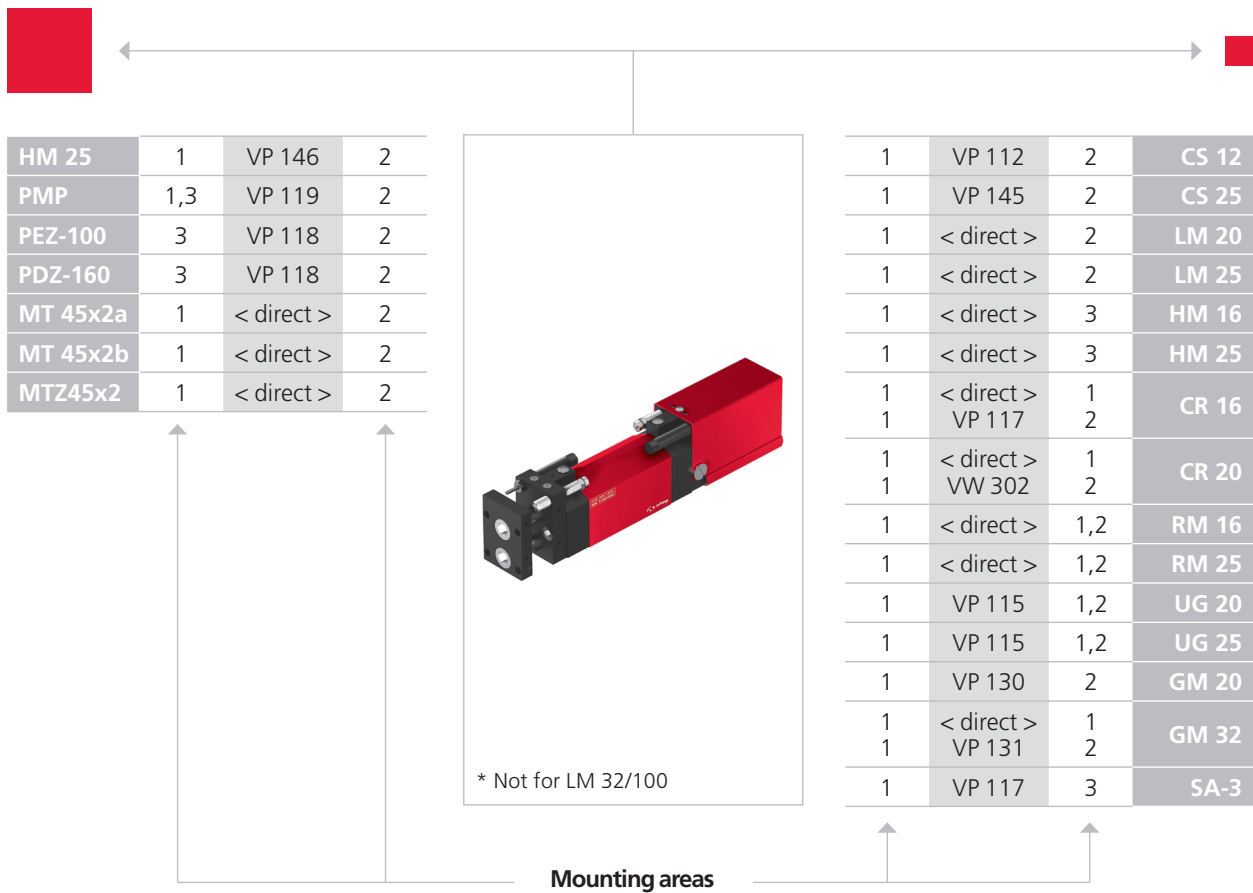

CS, ES 	LM 	HM 	SA 	UG, GM, SG, DG, PG, GE, SGE
PMP, PMP-c 	PEZ, PDZ 	PEL, PDL 	RM, RE 	CR, RM 32, RE, SREH, RA

Note that there might be different mounting positions from one module to another one.
The required connection elements and the range of support columns are depicted in the catalogue HT accessories.

Type	LM 32/100	LM 32/200	LM 32/300	LM 32/400
Max. static torque Mx	12 Nm	12 Nm	12 Nm	12 Nm
Max. static torque My	95 Nm	127 Nm	158 Nm	190 Nm
Max. static torque Mz	95 Nm	127 Nm	158 Nm	190 Nm
Max. dynamic torque Mx	5 Nm	5 Nm	5 Nm	5 Nm
Max. dynamic torque My	43 Nm	57 Nm	71 Nm	85 Nm
Max. dynamic torque Mz	43 Nm	57 Nm	71 Nm	85 Nm
Effective distance Wx	311 mm	411 mm	511 mm	611 mm

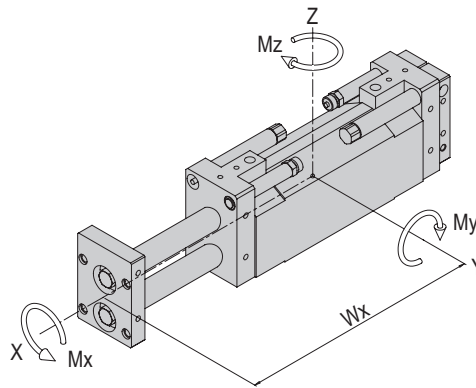

Maximum payload/type	LM 32/100	LM 32/200	LM 32/300	LM 32/400
Installation position (horizontal) for mounting side 1	10 kg	9 kg	7 kg	5 kg
Installation position (horizontal) for mounting side 3	10 kg	9 kg	7 kg	5 kg
Installation position (vertical) for mounting side 1	10 kg	9 kg	7 kg	5 kg
Installation position (vertical) for mounting side 3	10 kg	9 kg	7 kg	5 kg

Assembly sides
module mounting

horizontal:

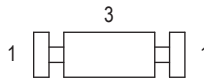

vertical:

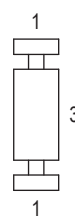

Operation time diagrams

Stroke time LM 32 with shock absorber

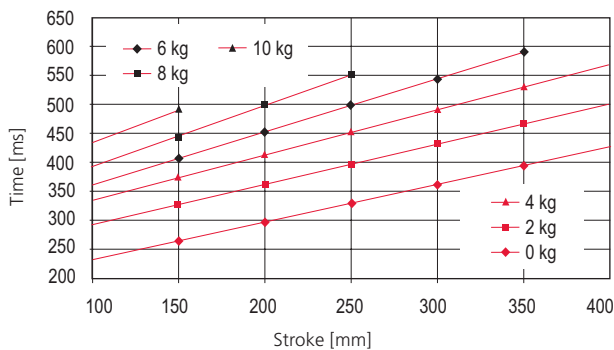

Base plate LM 12	LM 12/30	LM 12/60	LM 12/90
Order number	11010371	11010372	11010373
Net weight	0.1 kg	0.13 kg	0.16 kg
A	117 mm	147 mm	177 mm
B	112 mm	142 mm	172 mm
C	106 mm	136 mm	166 mm

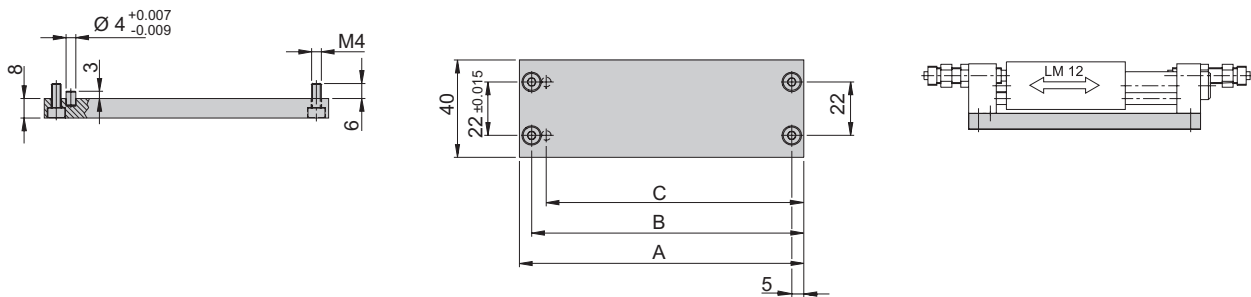

Stop L-bar LM 12/LM 16	LM 12/30 / LM 16/30	LM 12/60 / LM 16/60	LM 12/90 / LM 16/90
Order number	11001880	11001884	11001887
Net weight	0.08 kg	0.1 kg	0.12 kg
A	117 mm	147 mm	177 mm

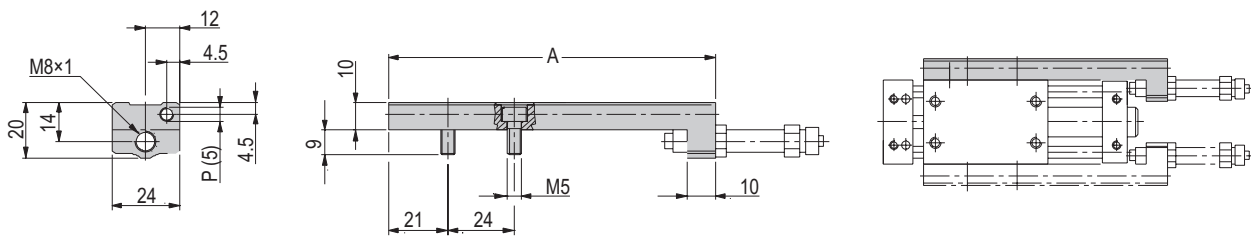

Base plate LM 16	LM 16/30	LM 16/60	LM 16/90
Order number	11001437	11001442	11001445
Net weight	0.21 kg	0.28 kg	0.32 kg
A	122.5 mm	152.5 mm	182.5 mm
B	104.5 mm	134.5 mm	164.5 mm

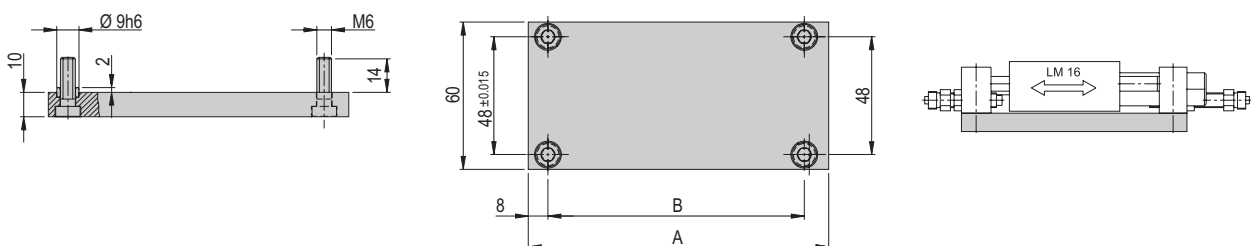

3. Position LM 20

Order number	11001623
Net weight	0.45 kg
A	*24 mm
B	extended
C	retracted

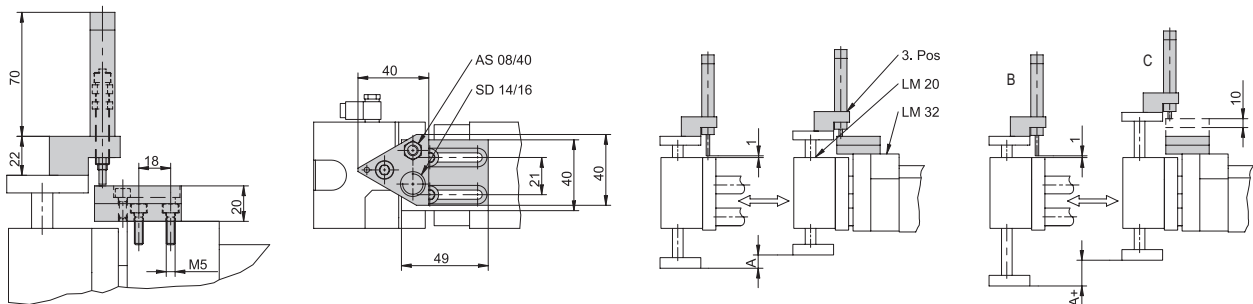

Note: Requirement: Module combination LM 32 with LM 20
 Purpose: Various removal and application heights can be covered between the retracted and extended states.
 Stroke difference grading: Standard = 10 mm
 1 additional plate = +10 mm
 Max. 3 additional plates possible

*LM 20/30 = 14 mm

Included in the delivery (Catalogue HT accessories)

- 1x Stop carrier
- 1x Contact plate
- 1x Intermediate contact plate
- 1x Shock absorber SD M14x1 -1
- 1x Stop screw AS 08/40

Intermediate contact plate

Order number	11001613
Net weight	0.137 kg

Base plate LM 20 / LM 25	LM 20/30	LM 20/60 / LM 25/60	LM 20/90	LM 20/120 / LM 25/120	LM 20/150	LM 20/200 / LM 25/200
Order number	11001619	11001624	11001626	11001628	11001630	11009423
Net weight	0.25 kg	0.35 kg	0.44 kg	0.54 kg	0.64 kg	0.85 kg
A	140.8 mm	200.8 mm	260.8 mm	320.8 mm	380.8 mm	480.8 mm
B	129 mm	189 mm	249 mm	309 mm	369 mm	469 mm

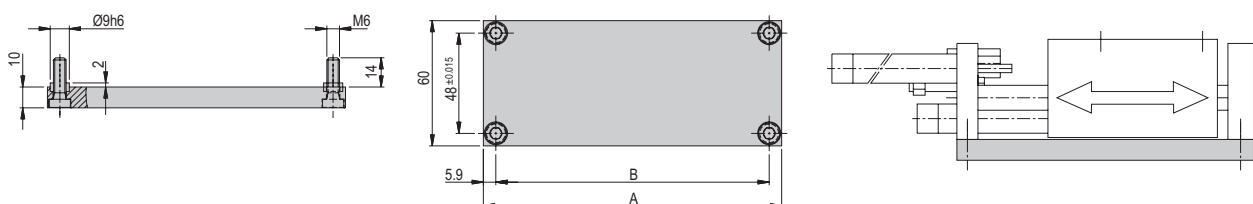

3. Position LM 25

Order number **11013401**

Net weight 0.45 kg

A 40 mm

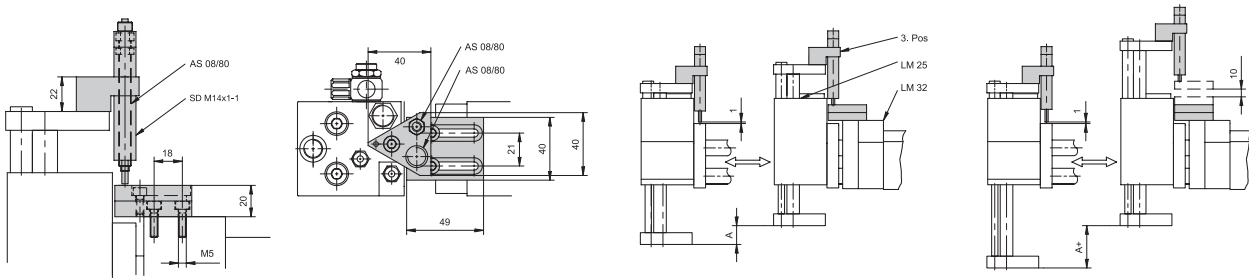

Note: Requirement: Module combination LM 32 with LM 25

Purpose: Various removal and application heights can be covered between the retracted and extended states.

Stroke difference grading: Standard = 10 mm

1 additional plate = +10 mm

Max. 3 additional plates possible

Included in the delivery

(Catalogue HT accessories)

- 1x Stop carrier
- 1x Contact plate
- 1x Intermediate contact plate
- 1x Shock absorber SD M14x1 -1
- 1x Stop screw AS 08/40

ZA 20/25

The intermediate stop can be installed acting forwards as well as backwards on the base plate ZA due to the symmetrical structure. Depending on how the base plate is installed, the intermediate stop can be fitted to the right or the left of the module. The head side of the stop screw is always oriented against the shock absorber. The base plate ZA and the stop serve for continuous intermediate position adjustment. The stop screw is fitted in the bore on the module slide and the intermediate stop is screwed into the desired position on the base plate.

With the intermediate stop, you can limit the extension or retraction stroke with an intermediate position.

Type	ZA 20/25
A	ZA extended (rear)
B	Position SD
C	ZA retracted (front)
D	Base plate
E	Stop screw
F	Intermediate stop

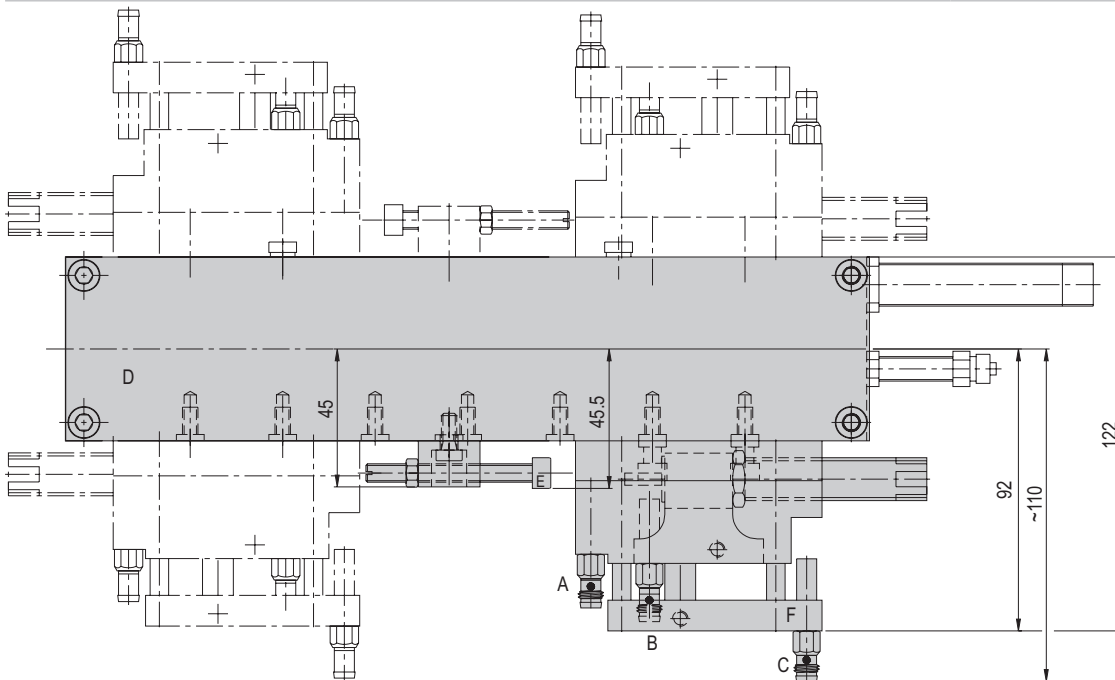

ZA 20/25 - LM 20

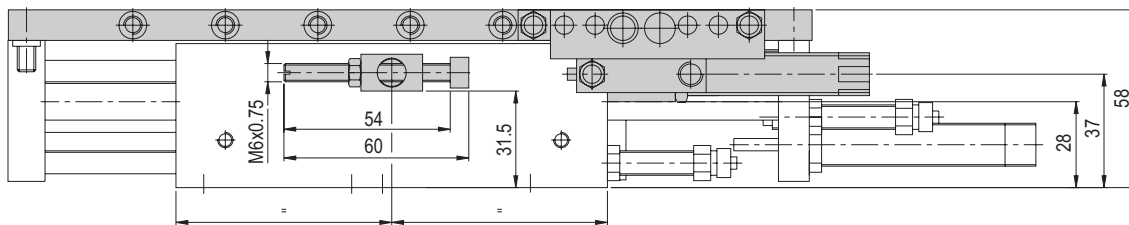

ZA 20/25 - LM 25

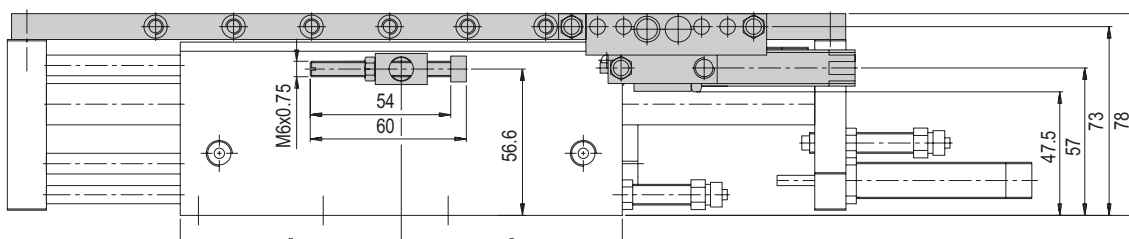

Base plate ZA LM 20 / LM 25	LM 20/60 LM 25/60	LM 20/90	LM 20/120 LM 25/120	LM 20/150	LM 20/200 LM 25/200
Order number	11011031	11011033	11011033	11011034	11011035
Net weight	0.34 kg	0.43 kg	0.53 kg	0.63 kg	0.84 kg
Number of interim attachments	1	1	1	1	1
A	200.8 mm	260.8 mm	320.8 mm	380.8 mm	480.8 mm
B	189 mm	249 mm	309 mm	369 mm	469 mm
C	25.4 mm	40.4 mm	55.4 mm	70.4 mm	90.4 mm
D	5	6	7	8	10

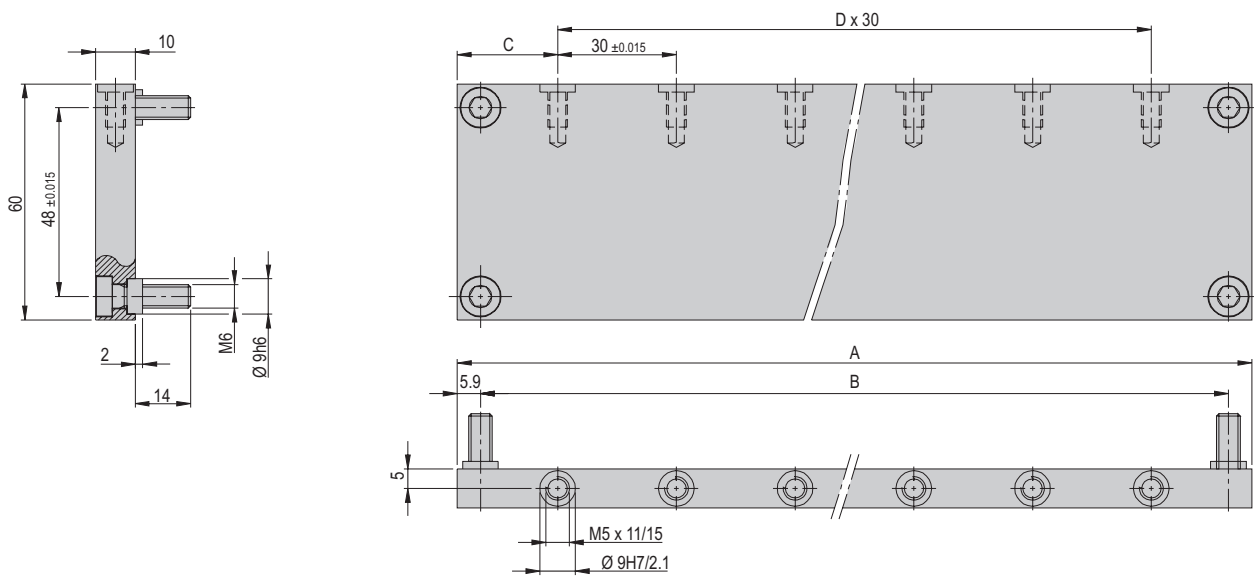

Note: No ZA is provided for the LM 20/30

Intermediate stop ZA 32	ZA 32
Order number	11009325
Net weight	0.574 kg
A	ZA retracted (bottom)*
B	ZA extended (top)*
C	Shock absorber damped
H	15 mm
P	M5

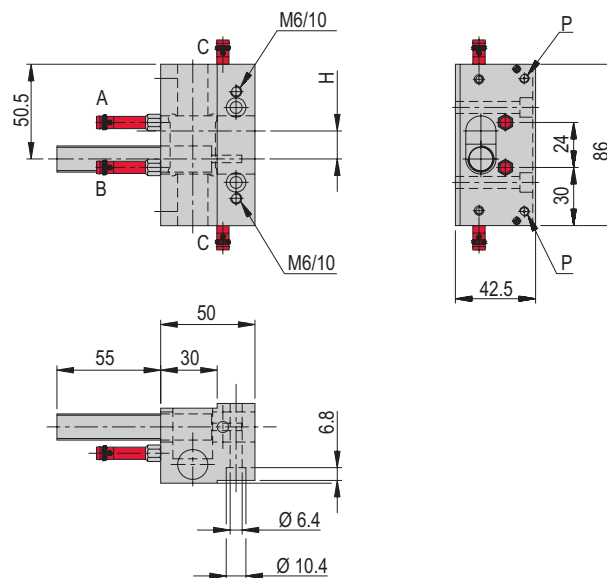

 Proximity switches

The technical data refer to a nominal pressure of 6 bar under Afag standard test conditions.
Note: A back or front stop rod, depending on the place of installation, must also be ordered.

*Proximity switch (optional)

Included in the delivery

(Catalogue HT accessories)

- 2x Mounting screw M6x45
- 1x Shock absorber SD M14x1 -1
- 2x Clamping nut M8x0.75

Accessories

- Back stop rod ZA 32 [p. 114]
 - Front stop rod ZA 32 [p. 113]
 - Narrow safety cover ZA 32 [p. 114]
 - Wide safety cover ZA 32 [p. 113]
- (Catalogue HT accessories)
- INI d6.5x44-Sn1.5-PNP-NO-M8x1

ZA 32

Should the ZA 32 be mounted up front to the LM 32 no extra safety cover is required. Mounted in the back depending on either one or both sides a «narrow» or «wide» cover is necessary. The covers have to be ordered seperately. The stop rods are needed for a continuous adjustability of the intermediate positions. It is recommended to always use the shortest possible stop rod.

Type	ZA 32/125	ZA 32/200	ZA 32/275
A	125 mm	200 mm	275 mm

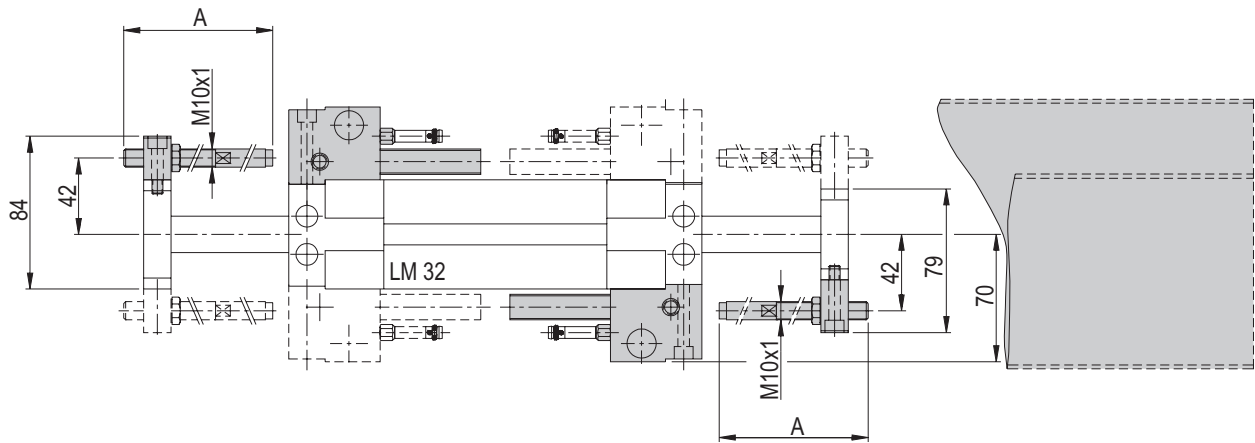

Front stop rod ZA 32	ZA 32/125	ZA 32/200	ZA 32/275
Order number	11010462	11010463	11010464
Net weight	0.139 kg	0.185 kg	0.23 kg
Suitable for	LM 32/100 LM 32/200 LM 32/300 LM 32/400	LM 32/200 LM 32/300 LM 32/400	LM 32/300 LM 32/400
A	125 mm	200 mm	275 mm
B	95 mm	95 mm	95 mm
SW	13 mm	13 mm	13 mm

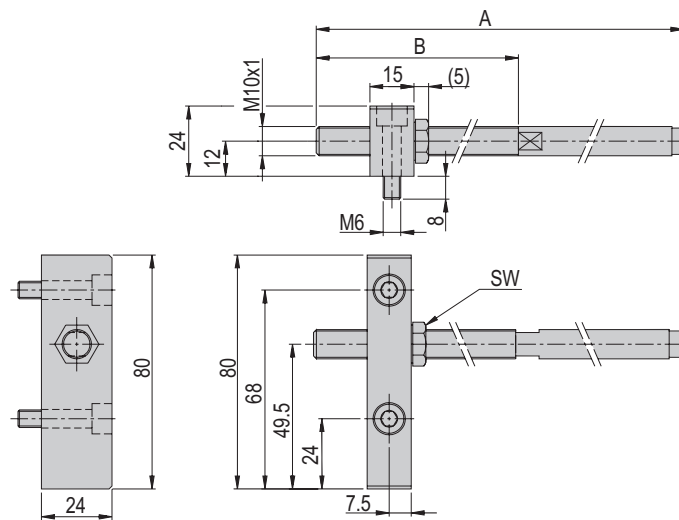

Included in the delivery

(Catalogue HT accessories)

- 2 Mounting screw M6x25
- 1x Nut M10x1 for ZA 32

Wide safety cover ZA 32	ZA 32/100	ZA 32/200	ZA 32/300	ZA 32/400
Order number	11010473	11010472	11010471	11010470
Net weight	0.82 kg	0.63 kg	0.445 kg	0.26 kg
Suitable for	LM 32/100	LM 32/200	LM 32/300	LM 32/400
A	139 mm	239 mm	339 mm	439 mm
B	89 mm	89 mm	89 mm	89 mm
C	148 mm	148 mm	148 mm	148 mm

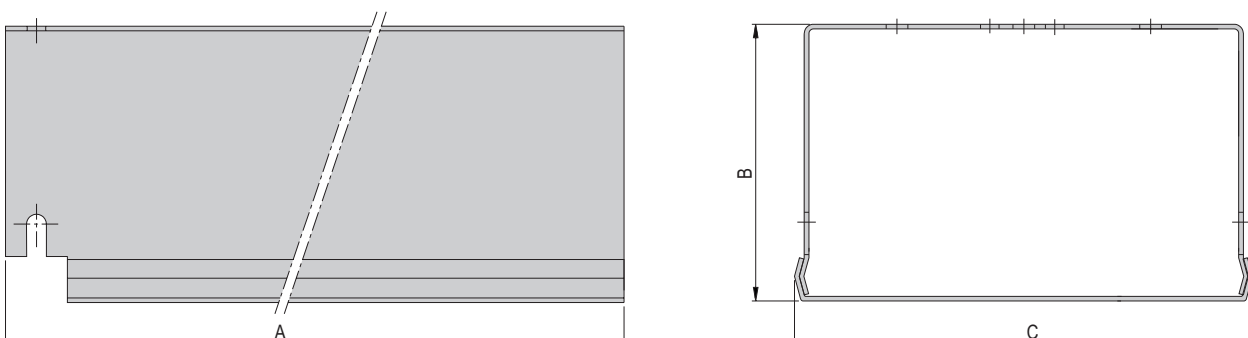

Back stop rod ZA 32	ZA 32/125	ZA 32/200	ZA 32/275
Order number	11009326	11009327	11009328
Net weight	0.15 kg	0.196 kg	0.241 kg
Suitable for	LM 32/100 LM 32/200 LM 32/300 LM 32/400	LM 32/200 LM 32/300 LM 32/400	LM 32/300 LM 32/400
A	125 mm	200 mm	275 mm
B	95 mm	95 mm	95 mm
SW	13 mm	13 mm	13 mm

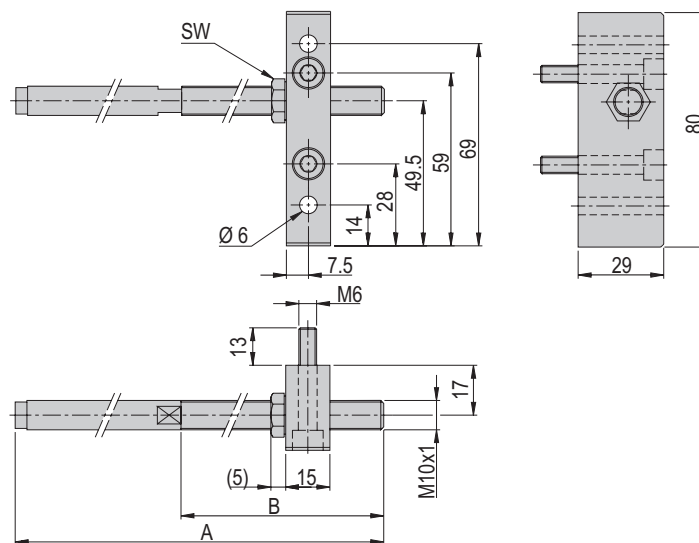

Included in the delivery
(Catalogue HT accessories)

- 2 Mounting screw M6x25
- 1x Nut M10x1 for ZA 32

Narrow safety cover ZA 32	ZA 32/100	ZA 32/200	ZA 32/300	ZA 32/400
Order number	11010466	11010467	11010468	11010469
Net weight	0.22 kg	0.375 kg	0.53 kg	0.69 kg
Suitable for	LM 32/100	LM 32/200	LM 32/300	LM 32/400
A	139 mm	239 mm	339 mm	439 mm
B	89 mm	89 mm	89 mm	89 mm
C	108 mm	108 mm	108 mm	108 mm

