

Proportional pressure reducing valve, pilot operated

RE 29177/07.05

1/10

Type DRE6X

Nominal size 6
 Unit series 1X
 Maximum working pressure P 315 bar, T 250 bar
 Maximum flow rate 40 l/min



List of Contents

Contents	
Features	1
Ordering data	2
Preferred types, symbol	2
Function, sectional diagram	3
Technical data	4
External trigger electronics	5 to 7
Characteristic curves	8
Unit dimensions	9

Features

Page	
1	– Pilot operated valves for reducing system pressure at the consumer (pilot oil internal only)
2	– 3-way version (P–A/A–T), $p_{\min} = p$ in T
2	– Adjustable by means of the solenoid current, see Characteristic Curve, Technical Data and selected valve electronics
3	
4	– Solenoid type $I_{\max} = 0.8$ A
5 to 7	– Pressure limitation to a safe level even with faulty electronics
8	(solenoid current $I > I_{\max}$)
9	– For subplate attachment, mounting hole configuration to ISO 4401-03-02-0-94 Subplates as per catalog sheet RE 45053 (order separately)
	– Plug-in connector to DIN 43650-AM2 included in scope of delivery
	– External trigger electronics with ramps and valve calibration in the following versions/designs (order separately)
	• Plug, setpoint 0...+10 V or 4...20 mA, RE 30264
	• Module, setpoint 0...+10 V, RE 30222
	• Europe card, setpoint 0...+10 V, RE 30109

Ordering data

DRE6	X-1X/	M	G24-8	N	Z4	M	*
Proportional 3-way pressure reducing valve NG6, pilot operated							Further information in plain text
Mounting hole configuration to ISO 4401-03-02-0-94	= X					M =	NBR seals, suitable for mineral oils (HL, HLP) to DIN 51524
Unit series 10 to 19 (10 to 19: installation and connection dimensions unchanged)	= 1X				Z4 =		Electrical connection Unit plug to DIN 43650-AM2 Plug-in connector included in scope of delivery
Max. pressure stage up to 75 bar up to 175 bar up to 310 bar						N =	Manual auxiliary override
Without non-return valve		= M		8 =			Solenoid type (current) Solenoid current 0.8 A max.
Voltage supply of trigger electronics 24 V DC			= G24				

Preferred types

Solenoid 0.8 A	
Type	Material Number
DRE6X-1X/75MG24-8NZ4M	0 811 402 059
DRE6X-1X/175MG24-8NZ4M	0 811 402 055
DRE6X-1X/310MG24-8NZ4M	0 811 402 058

Symbol

For external trigger electronics

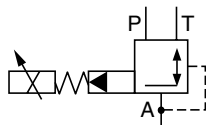

Function, sectional diagram

General

Type DRE6X proportional pressure reducing valves are pilot operated, with a 3-way main stage. The pilot valve (pressure relief valve pilot stage) is supplied internally with a controlled flow of pilot oil via P.

The valves are actuated by a proportional solenoid acting against a spring. The solenoid armature is cushioned to aid stability. The interior of the solenoid is filled with pressure fluid and connected via T.

Bleeding is achieved by means of a screw plug.

With these valves, the pressure in A (consumer) can be infinitely adjusted and reduced in relation to the solenoid current.

Basic principle

To adjust the system pressure in A, a setpoint is set in the trigger electronics. Based on this setpoint, the electronics control the solenoid coil with regulated PWM (pulse-width-modulated) current. The current is modulated with a dither, to ensure minimal hysteresis.

The proportional solenoid converts the current to a mechanical force, and the armature plunger pre-stresses the main spring in the pilot stage. The pilot stage is supplied with oil from P at a flow rate of <math><0.6 \text{ l/min}</math> via a flow control valve. The pilot pressure is compared with the consumer pressure (plus spring) in A and regulated (P-A/A-T).



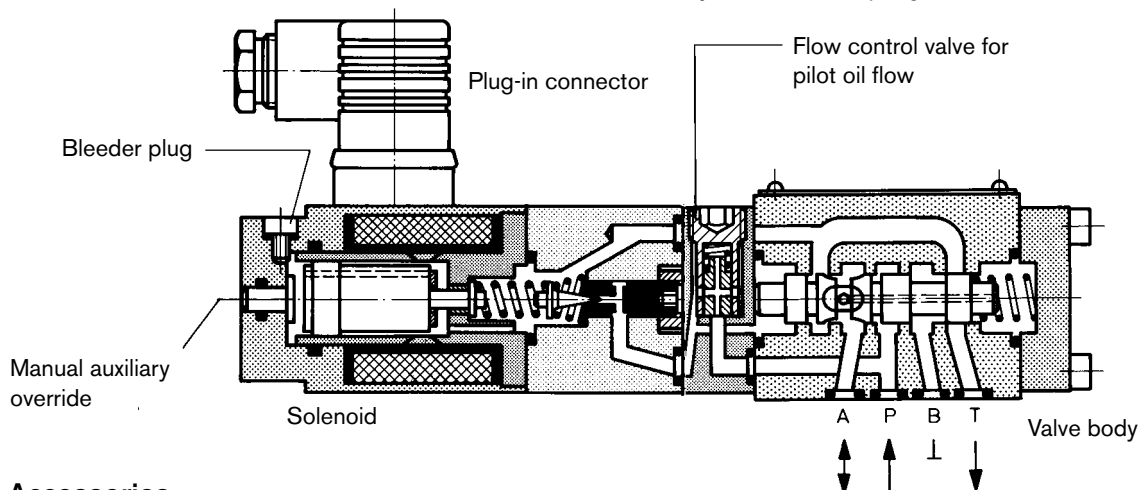

The spring results in $p_{Amin} = p$ in T.

Pressure limitation for maximum safety

If a fault occurs in the electronics, so that the solenoid current (I_{max}) would exceed its specified level in an uncontrolled manner, the pressure cannot rise above the level determined by the maximum spring force.

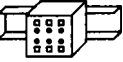

Accessories

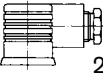
Type		Material Number
(4 x)  ISO 4762-M5x30-10.9	Cheese-head bolts	2 910 151 166
Plug 	VT-SSPA1-508-20/V0 (0.8 A)	RE 30264
	VT-SSPA1-508-20/V0/I (0.8 A)	
Module 	VT-MSPA1-508-10/V0 (0.8 A)	RE 30222
Europe card 	VT-VSPA1-508-10/V0/RTP (0.8 A)	RE 30109
Plug-in connector 	Plug-in connector 2P+PE (M16x1.5) included in scope of delivery, see also RE 08008	

Testing and service equipment

Test box type VT-PE-TB1, see RE 30063

Current measuring adapter type VT-PA-5, see RE 30073

Technical data

General		
Construction	Pilot stage	Poppet valve
	Main stage	Spool valve
Actuation		Proportional solenoid without position control, external amplifier
Connection type		Subplate, mounting hole configuration NG6 (ISO 4401-03-02-0-94)
Mounting position		Optional
Ambient temperature range	°C	-20...+50
Weight	kg	2.3
Vibration resistance, test condition		Max. 25 g, shaken in 3 dimensions (24 h)

Hydraulic (measured with HLP 46, $\vartheta_{\text{Oil}} = 40\text{ °C} \pm 5\text{ °C}$)

Pressure fluid		Hydraulic oil to DIN 51524...535, other fluids after prior consultation		
Viscosity range	recommended	mm ² /s	20...100	
	max. permitted	mm ² /s	10...800	
Pressure fluid temperature range	°C	-20...+80		
Maximum permitted degree of contamination of pressure fluid Purity class to ISO 4406 (c)		Class 18/16/13 ¹⁾		
Direction of flow		See symbol		
Max. set pressure in A (at $Q_{\text{min}} = 1\text{ l/min}$)	bar	75	175	310
Minimum pressure in A	bar	0 (relative) or pressure in T		
Min. inlet pressure in P	bar	$p_P = p_A + \geq 5$		
Max. working pressure	bar	Port P: 315		
Max. pressure	bar	Port T: 250 (B sealed)		
Internal pilot oil flow	l/min	approx. 0.6 (with closed-loop control)		
Max. flow	l/min	40		

Electrical

Cyclic duration factor	%	100
Degree of protection		IP 65 to DIN 40050 and IEC 14434/5
Solenoid connection		Unit plug DIN 43650/ISO 4400, M16x1.5 (2P+PE)
Max. solenoid current	I_{max}	0.8 A
Coil resistance R_{20}	Ω	22
Max. power consumption at 100% load and operating temperature	VA	25

Static/Dynamic²⁾

Hysteresis	%	≤ 4	
Manufacturing tolerance for p_{max}	%	≤ 10	
Response time 100% signal change	ms	On 200	Response time at: $Q = 10\text{ l/min}$ (values depend on the dead volume)
		Off < 250	

¹⁾ The purity classes stated for the components must be complied with in hydraulic systems. Effective filtration prevents problems and also extends the service life of components. For a selection of filters, see catalog sheets RE 50070, RE 50076 and RE 50081.

²⁾ All characteristic values ascertained using amplifier 0 811 405 081 for the 0.8 A solenoid.

Valve with external trigger electronics (plug, RE 30264)

Circuit diagram/pin assignment

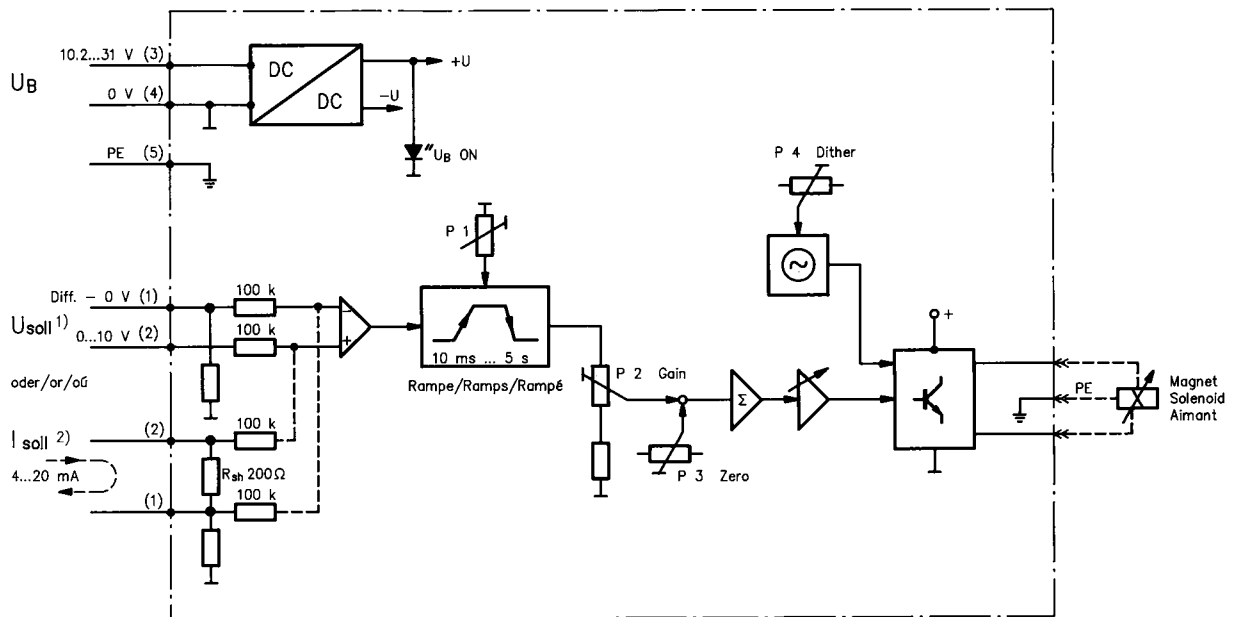

1) Version with 0...+10 V signal

2) Version with 4...20 mA signal

Connection/calibration

P1 – Ramp time

P2 – Sensitivity

P3 – Zero

P4 – Dither frequency

St1 – Terminal

LED – U_B display

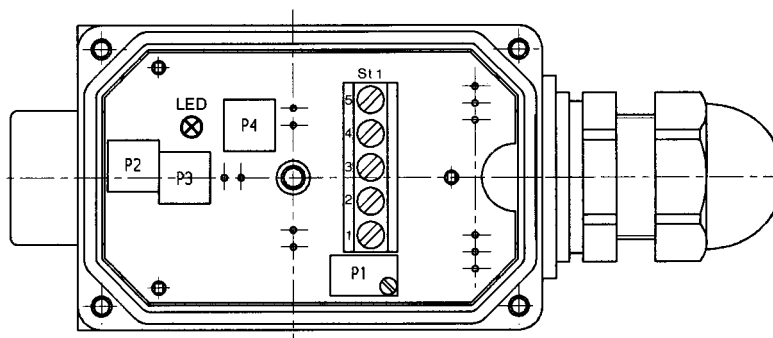

Valve with external trigger electronics (module, RE 30222)

Circuit diagram/pin assignment

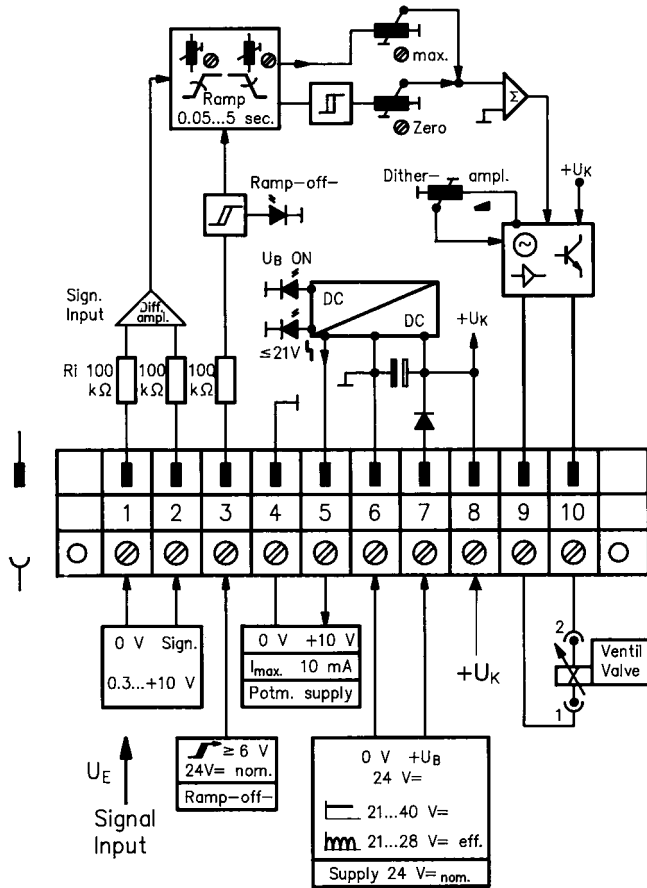

Front view/calibration

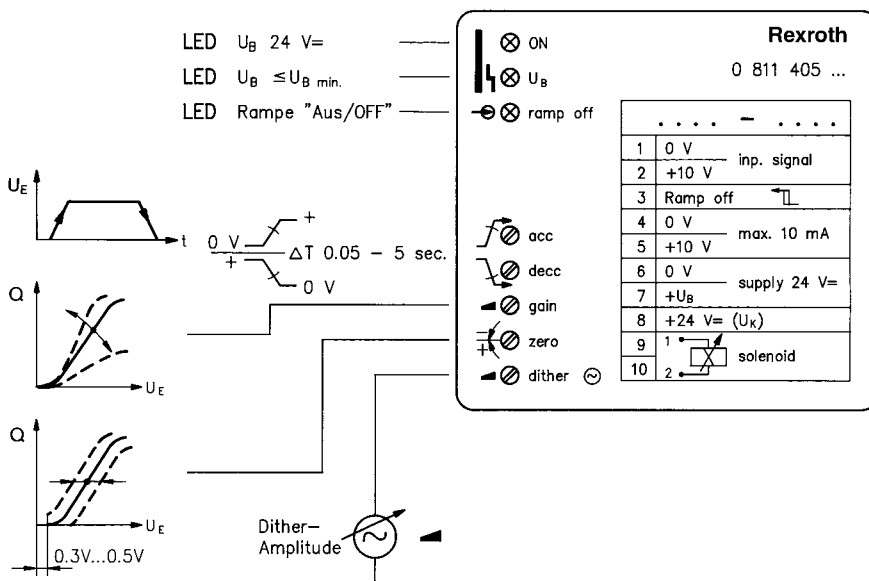

Valve with external trigger electronics (europe card, RE 30109)

Circuit diagram/pin assignment

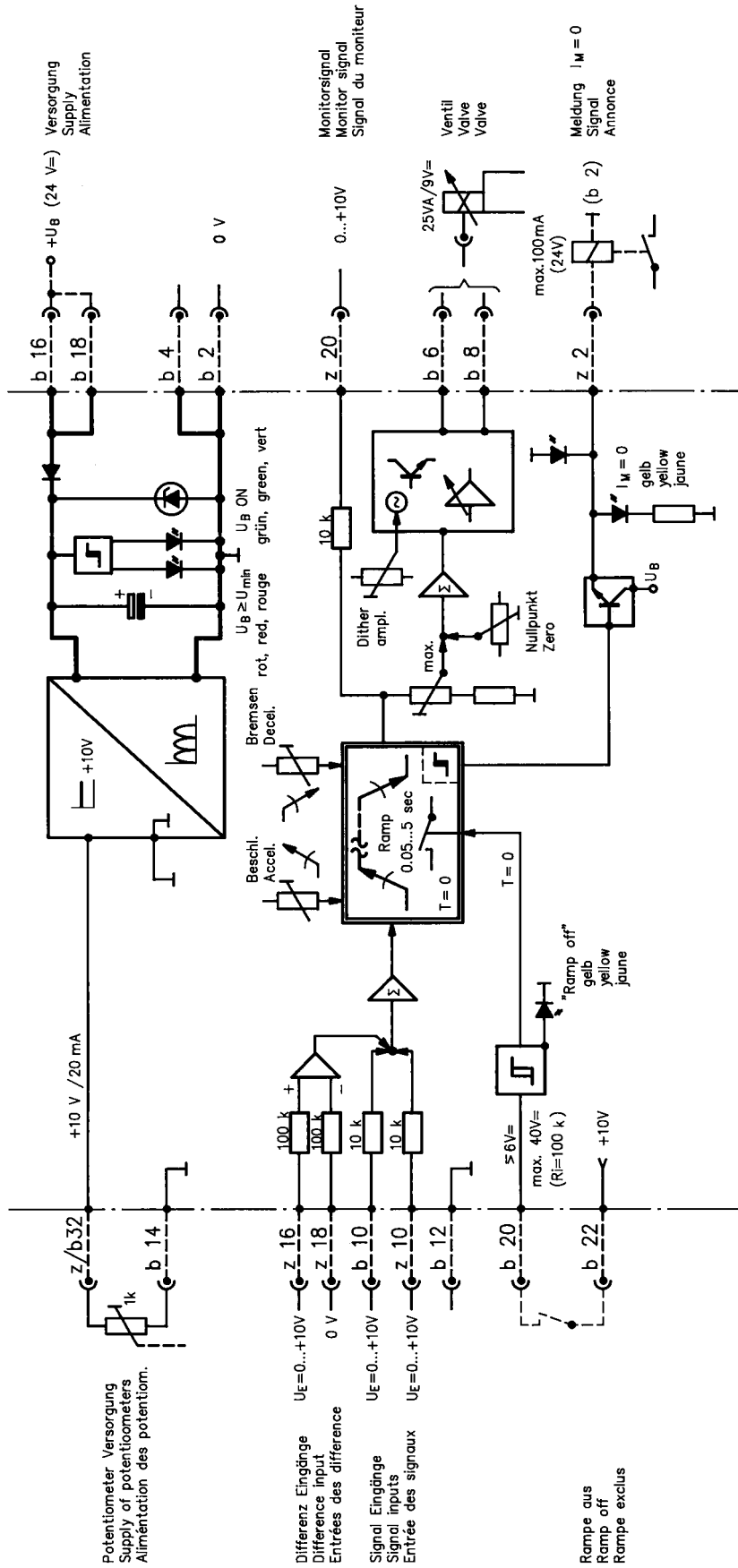

Characteristic curves (measured with HLP 46, $\vartheta_{oil} = 40^\circ\text{C} \pm 5^\circ\text{C}$)

Pressure in port A as a function of the setpoint

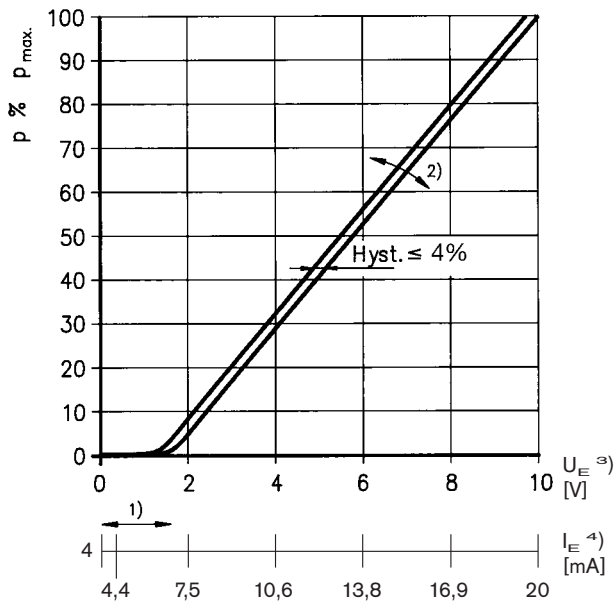

Valve amplifier

- 1) Zero adjustment
- 2) Sensitivity adjustment
- 3) Version: $U_E = 0 \dots +10 \text{ V}$
- 4) Version: $I_E = 4 \dots 20 \text{ mA}$

Pressure in port A proportionate to the maximum flow rate of the main stage

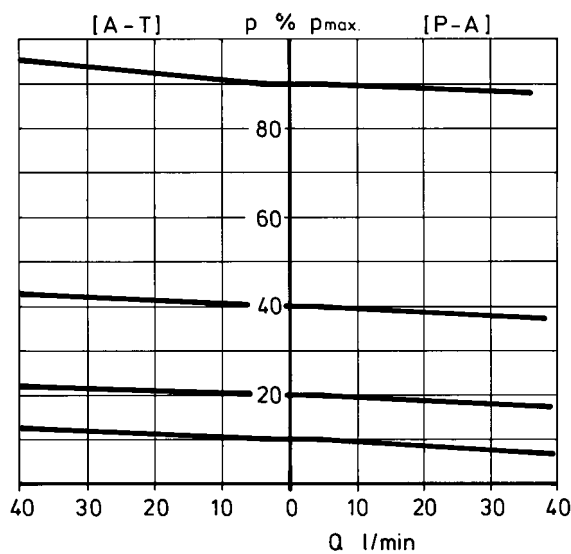

Set pressure

$$p \% p_{max} = f(Q_{P-A}/Q_{A-T})$$

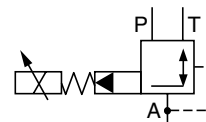

Unit dimensions (nominal dimensions in mm)

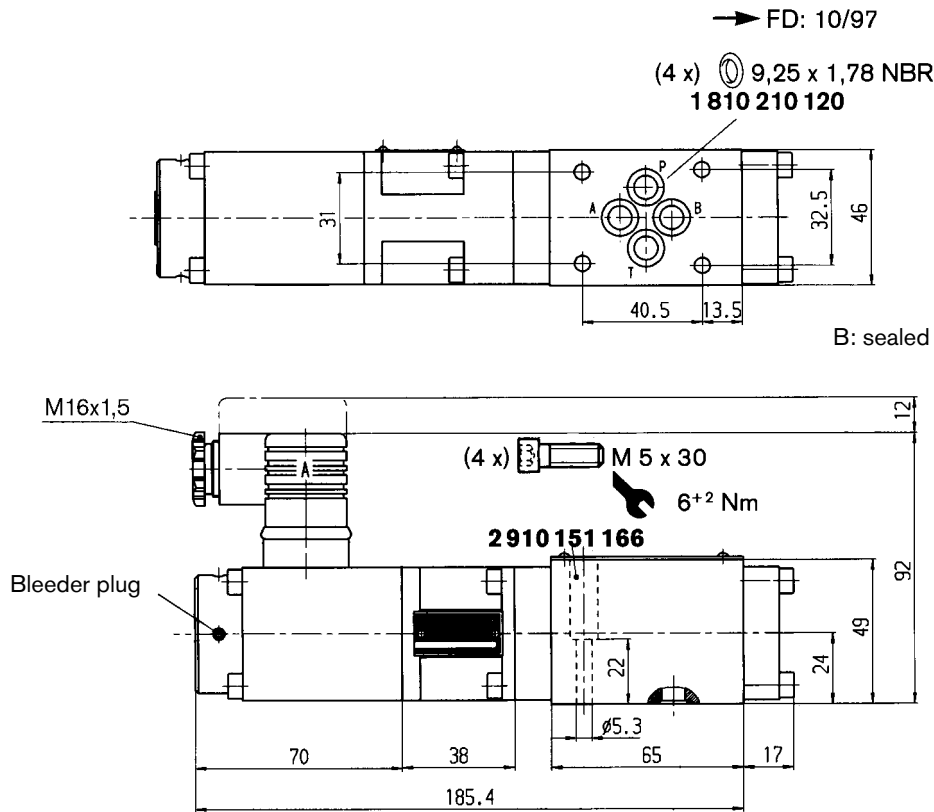

Mounting hole configuration: NG6 (ISO 4401-03-02-0-94)
 For subplates see catalog sheet RE 45053

- 1) Deviates from standard
- 2) Thread depth:
 Ferrous metal 1.5 x Ø
 Non-ferrous 2 x Ø

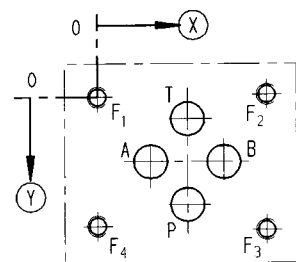

	P	A	T	B	F ₁	F ₂	F ₃	F ₄
⊗	21.5	12.5	21.5	30.2	0	40.5	40.5	0
⊙	25.9	15.5	5.1	15.5	0	-0.75	31.75	31
∅	8 ¹⁾	8 ¹⁾	8 ¹⁾	8 ¹⁾	M5 ²⁾	M5 ²⁾	M5 ²⁾	M5 ²⁾

Notes

Notes

Bosch Rexroth AG
Hydraulics
Zum Eisengießer 1
97816 Lohr am Main, Germany
Telefon +49 (0) 93 52 / 18-0
Telefax +49 (0) 93 52 / 18-23 58
documentation@boschrexroth.de
www.boschrexroth.de

© This document, as well as the data, specifications and other information set forth in it, are the exclusive property of Bosch Rexroth AG. It may not be reproduced or given to third parties without its consent.
The data specified above only serve to describe the product. No statements concerning a certain condition or suitability for a certain application can be derived from our information. The information given does not release the user from the obligation of own judgement and verification. It must be remembered that our products are subject to a natural process of wear and aging.

Notes

Bosch Rexroth AG
Hydraulics
Zum Eisengießer 1
97816 Lohr am Main, Germany
Telefon +49 (0) 93 52 / 18-0
Telefax +49 (0) 93 52 / 18-23 58
documentation@boschrexroth.de
www.boschrexroth.de

© This document, as well as the data, specifications and other information set forth in it, are the exclusive property of Bosch Rexroth AG. It may not be reproduced or given to third parties without its consent.
The data specified above only serve to describe the product. No statements concerning a certain condition or suitability for a certain application can be derived from our information. The information given does not release the user from the obligation of own judgement and verification. It must be remembered that our products are subject to a natural process of wear and aging.