

## ST96-35.04

Differential temperature controller

Order number 900146.002



## Wiring diagram

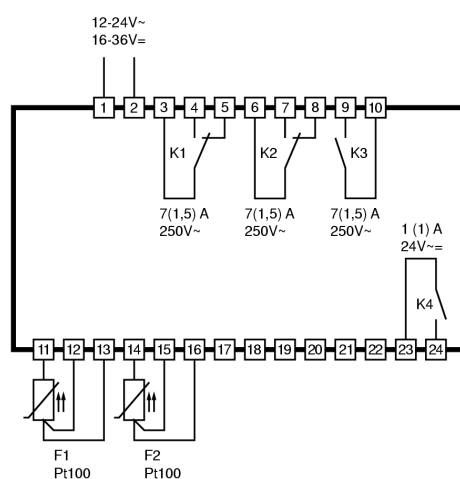

## Product description

The differential temperature controller with two 4-digit LED seven segment display, 3 keys and 4 relays is variably applicable due to its freely programmable general functions. The relay contact K1 directly affects the main setpoint, formed by reference variable and the given offset temperature. Contact K2 affects the secondary setpoint which is formed by the main desired value via overlap or which alternatively can be freely defined. Contact K3 affects adjustable limit values

**Sensor:** Pt100

**Range:** -200...850°C

**Front size:** 96mm x 96mm

**Panel cut-out:** 90,5mm x 90,5mm

**Connector:** plug and socket

ST 96...

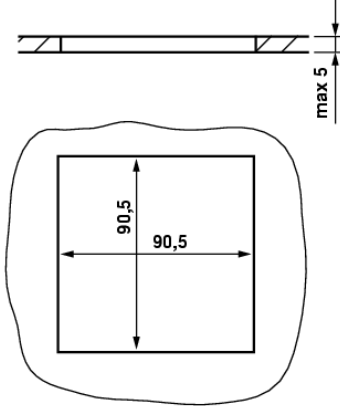
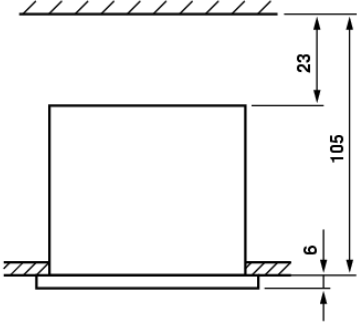
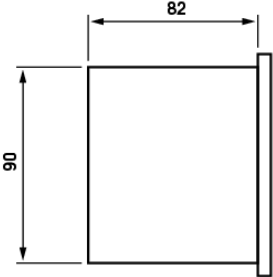
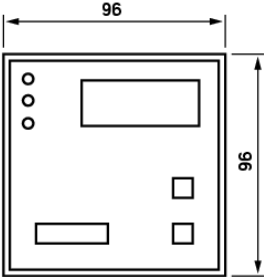

## SOFTWARE .04

### Adjustment options



#### **Key UP**

Pressing this key you can increase the parameter or parameter value or scroll the parameter list.



#### **Key DOWN**

Pressing this key you can decrease the parameter or parameter value or scroll the parameter list. At alarm the buzzer function can be switched off with this key.



#### **Key SET**

Holding this key, the desired value is indicated. Additionally, this key is used for setting parameters.

### **General information**

The relay contact K1 directly affects the main setpoint, formed by reference variable and the given offset temperature. Contact K2 affects the secondary setpoint which is formed by the main setpoint via overlap or which alternatively can be freely defined. An alarm contact affects adjustable limit values. The outputs are exchangeable with parameter adjustments, in order to achieve an optimal relation of the existing hardware with regard to contact rating, kind of contact and cycle number.

### **First control level:**

#### **Parameter setting of the main setpoint**

If none of the keys is pressed, the display indicates the actual value of the temperature. Pressing the SET key, the setpoint (difference value) shows on the display.

If the setpoint is to be changed, the SET key is to be kept pressed while adjusting the setpoint with the keys UP and DOWN.

Please note that the setpoint can only be changed within the set setpoint limits.

The setpoint S1' (if available) can be adjusted in the same way. If setpoint S1' is activated it is indicated and relevant for the control in case of closed switching input.

Parameter	Function description	Adjustment range	Standard setting	Custom setting
<b>S1</b>	Setpoint 1, difference value	P4 ... P5	0.0°C	
<b>S1'</b>	Sollwert 1', difference value or freely adjustable setpoint	-99.0 ... +99.0 K (if A33=1) -99 ... 999°C (if A33=2)	0.0°C/K	

### Second control level (P parameters):

#### Setting of control parameters

Simultaneously pressing the UP and DOWN key for at least 4 seconds opens a parameter list containing control parameters. With the UP and DOWN keys the list can be scrolled in both directions. Pressing the SET key will give you the value of the respective parameter. Pressing also the UP or DOWN key at the same time the value can be adjusted.

Return to the initial position takes place automatically, if no key is pressed for 60 seconds.

Parameter	Function description	Adjustment range	Standard setting	Custom setting
P1**	Setpoint 2 or Delta W	-99 ... 999°C -99 ... 99.9 K	+10.0 K	
P2*	Hysteresis contact K1	0.1 ... 99.9 K	1.0 K	
P3**	Hysteresis contact K2	0.1 ... 99.9 K	1.0 K	
P4	Control range limitation – minimum difference value	-99°C ... P5	-99°C	
P5	Control range limitation – maximum difference value	P4 ... 999°C	99°C	
P7***	Proportional band	0.1 ... 99.9 K	20.0 K	
P8***	I-factor	0 ... 15	8	
P9***	D-factor	0 ... 15	8	
P10***	Cycle time	8 ... 100 sec.	20 sec.	
P19	Key-lock	0: no key-lock 1: key-lock	0	
P20	Following value display	-----	-----	
P21	Following value correction	-10.0 ... 10.0 K	0.0 K	
P22	Leading value display	-----	-----	
P23	Leading value correction	-10 ... 10.0 K	0.0 K	
P30	Lower limit value of the following value for alarm contact	-99°C/K ... P31	-10 K	
P31	Upper limit value of the following value for alarm contact	P30 ... 999°C/K	+10.0 K	
P32	Lower range limitation for fixed setpoint control	-99 ... 999°C	-99°C	
P33	Upper range limitation for fixed setpoint control	-99 ... 999°C	999°C	
P40****	Analogue output	0: PID-control value (P43-P45) 1: following value (P41, P42) 2: leading value (P41, P42)	0	
P41****	Indication value for 0V at analogue output	-99 ... 999°C	0°C	
P42****	Indication value for 10V at analogue output	-99 ... 999°C	100°C	
P43****	Indication value full heating performance (100%)	-10.0 ... +10.0 V	+10.0 V	
P44****	Indication value "0" performance	-10.0 ... +10.0 V	0.0 V	
P45****	Indication value full cooling performance (100%)	-10.0 ... +10.0 V	-10.0 V	

\* only available if K1 operates as thermostat

\*\* only available if K2 operates as thermostat

\*\*\* only available if K1 or K2 operates in PID mode

\*\*\*\* only available if there is an analogue output

## Parameter description:

### **P1: Setpoint / DeltaW for control circuit 2**

Adjusting the setpoint of control circuit 2.

If A5=1, the setpoints for control circuit 1 and 2 are linked with one another via switching difference DeltaW, which can be adjusted with P1. (operation with DeltaW)

The following applies: setpoint thermostat 2 = setpoint control circuit 1 + delta W2.

This difference can take positive or negative values. Thus, a leading or following contact can be realised.

If A5=0, the setpoints for control circuit 1 and 2 are independently adjustable.

### **P2: Hysteresis contact K1 (only available if K1 in thermostatic mode)**

### **P3: Hysteresis contact K2 (only available if K2 in thermostatic mode)**

The hysteresis is set symmetrically at the setpoint, i.e. half of the hysteresis' value is effective below and half of the value above the switching point.

### **P4: Control range limitation – minimum difference value**

### **P5: Control range limitation – maximum difference value**

The adjustment range of the setpoint can be limited in both directions. This is to prevent the end user of a unit from setting inadmissible or dangerous setpoints.

## **Parameters P7...P10 are only available if either K1 or K2 operates in PID mode (A6 = 1 or A7 = 1)**

### **P7: Proportional band at PID regulation**

The proportional part works in such a way that with approximation of the actual value to the setpoint the variable is reduced linearly from +-100% to 0%.

### **P8: I-factor**

### **P9: D-factor**

These settings determine the intensity and effect of the I- and D-portion. If "0" is set, then the portion is inactive.

### **P10: Cycle time**

The cycle time is the time, in which the control output runs through one switching period, i.e. once switched out and once switched on. The smaller the cycle time, the faster the regulation. By consequence, however, there is also an increased switching frequency of the exit, which can lead to rapid wear of relay contacts. For very fast control ways with the respective high switching frequency a voltage output is therefore of advantage.

### **P19: Key-lock**

The key-lock allows blocking of the control keys. In locked condition parameter adjustments with keys is not possible. At the attempt to adjust the parameters despite key-lock the message "===" appears in the display.

### **P20: Following value display**

When this parameter is selected, pressing the SET key display the actual value of the following input. The value can be adjusted with parameter P21.

### **P21: Following value correction**

This parameter allows the correction of actual value deviations caused for example by sensor tolerances or extremely long sensor lines. The regulation measure value is increased or decreased by the here adjusted value.

## **P22: Leading value display**

When this parameter is selected, pressing the SET key display the actual value of the leading input. The value can be adjusted with parameter P23.

## **P23: Leading value correction**

This parameter allows the correction of actual value deviations caused for example by sensor tolerances or extremely long sensor lines. The regulation measure value is increased or decreased by the here adjusted value.

## **P30: Lower alarm value**

## **P31: Upper alarm value**

The exit alarm is a boundary alarm or a range alarm. Both at the boundary alarm and the range alarm, limit values can be relative, i.e. going along with the setpoint S1/S1', or absolute, i.e. independent of the setpoint S1/S1'.

If only one switching point is required in case of boundary alarm, the not-used second switching point should be adjusted to a value above or below the control range and the limit values should be absolute (see parameter A30).

## **P32: Lower range limitation for fixed setpoint control on following sensor**

## **P33: Upper range limitation for fixed setpoint control on following sensor**

P32 and P33 are the limit values for the main setpoint, formed by reference variable and the given offset temperature. If the main setpoint is above the upper or below the lower limit value the value of P32 or P33 becomes effective as new setpoint and the leading value has no more effect on the setpoint. When the temperature range between P32 and P33 is reached again the control returns to the main setpoint as before.

## **P40: Analogue output**

This is to define whether the analogue output carries reference variable, the actual following value or the actual leading value. In case of reference variable display, the sign can change, depending on whether heating or cooling is required. The actual values, however, are always indicated with positive sign.

## **P41: Indication value for 0V at analogue output**

## **P42: Indication value for 10V at analogue output**

Indication of the actual value is subject to the following range adjustment:

If temperature reaches the value set in P41, voltage is 0 V.

If temperature reaches the value set in P42, voltage is 10 V.

## **P43: Indication value full heating performance (100%)**

## **P44: Indication value "0" performance**

## **P45: Indication value full cooling performance (-100,0%)**

Indication of the variable is subject to the following range adjustment:

If heating is to be performed with 100 %, voltage is as set at P43.

If neither heating nor cooling is requested, voltage is as set at P44.

If cooling is to be performed with 100 %, voltage is as set at P45.

Scaling example 1:  
 Indication range of the variable for heating and cooling is  $-10,0 \dots +10,0 \text{ V}$   
 with  $P43 = 10,0$ ;  $P44 = 0,0$ ;  $P45 = -10,0$ .  
 This is the standard setting.

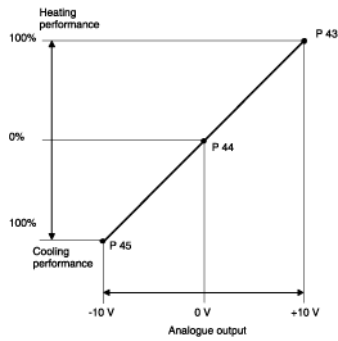

Fig. 1

Scaling example 2:  
 Indication range of the variable for heating is  $+2,0 \dots +10,0 \text{ V}$   
 with  $P43 = 10,0$ ;  $P44 = 2,0$ ;  $P45 = 2,0$ .

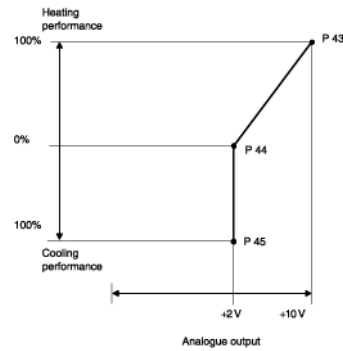

Fig. 2

Scaling example 3:  
 Indication range of the variable for cooling is  $-2,0 \dots -8,0 \text{ V}$   
 with  $P43 = -2,0$ ;  $P44 = -2,0$ ;  $P45 = 8,0$ .

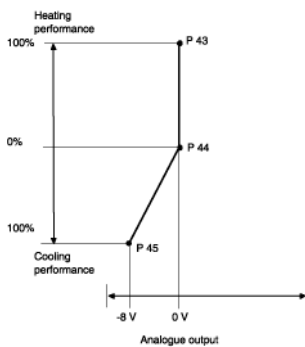

Fig. 3

### Notes concerning parameters P40 - P45:

If the reference variable is selected with parameter P40, the parameters P41 and P42 are still adjustable, but without function. The same applies to the parameters P43-P45, if the actual value is selected with parameter P40.

### Third control level (A-parameters):

#### Setting of control parameters

Access to the third control level is granted when selecting the last P-parameter on the second control level. Continue to press the UP key for approximately 10 seconds until "PA" appears. Continue to press the UP key and additionally press the DOWN key for about 4 seconds and the first A-parameter of the third control level is indicated.

With the keys UP and DOWN you can scroll the list in both directions. Pressing the SET key will give you the value of the respective parameter. By pressing the UP or DOWN key at the same time the value can be adjusted.

Return to the initial position takes place automatically, if no key is pressed for 60 seconds, or by simultaneously pressing the UP and DOWN key for approx. 4 seconds.

Parameter	Function description	Adjustment range	Standard setting	Custom setting
<b>A1</b>	Switch mode contact K1	0: heating contact 1: cooling contact	0	
<b>A2</b>	Switch mode contact K2	0: heating contact 1: cooling contact	1	
<b>A3</b>	Function of contact K1 at sensor error	0: relay off 1: relay on	0	
<b>A4</b>	Function of contact K2 at sensor error	0: relay off 1: relay on	0	
<b>A5</b>	Selection setpoint 2 or DeltaW	0: operation with setpoint 2 1: operation with DeltaW	1	
<b>A6</b>	Control characteristics contact K1	0: thermostatic 1: PID	1	
<b>A7</b>	Control characteristics contact K2	0: thermostatic 1: PID	0	
<b>A8</b>	Display mode	0: integrals, without leading zeros 1: with decimals, without leading zeros 2: integrals, with leading zeros 3: with decimals, with leading zeros	1	
<b>A9</b>	Temperature scale	0: Celsius 1: Fahrenheit 2: Kelvin	0	
<b>A10</b>	Indication value for lower value linear analogue input	-99 ... 999°C	0°C	
<b>A11</b>	Indication value for upper value linear analogue input	-99 ... 999°C	100°C	
<b>A19</b>	Parameter lock	0: no lock 1: A-parameter locked 2: A- and P-parameter locked	0	
<b>A30</b>	Function alarm exit	0: Boundary alarm, relative 1: Boundary alarm, absolute 2: Range alarm, relative 3: Range alarm, absolute	0	



Parameter	Function description	Adjustment range	Standard setting	Custom setting
<b>A31</b>	Special function at boundary alarm	0: no special function 1: flashing display 2: buzzer 3: flashing display and buzzer	0	
<b>A32</b>	Special display (at Pos. 4+5 setpoint display if no differential control)	0: not active 1: upper display always indicates setpoint 2: lower display always indicates setpoint 3: lower display always indicates setpoint, if no differential mode 4: upper display always indicates desired difference value 5: lower display always indicates desired difference value 6: upper display always indicates actual difference value 7: lower display always indicates actual difference value	0	
<b>A33</b>	Type of setpoint S1'	0: S1' not active 1: relative of setpoint S1 2: absolute value	0	

## Parameter description

*The following values can change the equipment characteristics and are therefore to be set with utmost care.*

### **A1: Switch mode contact K1**

### **A2: Switch mode contact K2**

The switch mode for the relays, i.e. cooling or heating function, can be programmed independently at works. Heating function means that the contact opens as soon as the setpoint is reached, thus power interruption. At cooling function the contact closes, if the actual value is above the required setpoint.

### **A3: Function of contact K1 at sensor error**

### **A3: Function of contact K2 at sensor error**

In case of open-circuit or short-circuit at sensor 1 the display indicates a flashing "F1", at sensor 2 a flashing "F2". At sensor error the selected relay falls back into the condition pre-set here.

### **A5: Selection setpoint 2 or DeltaW**

This parameter determines whether the setpoints for thermostat 1 and 2 independently adjustable (A5=0) or whether they are tied with one another via a switching offset DeltaW (A5=1). This parameter applies only to contact K2 (see parameter P1).

### **A6: Control characteristics contact K1**

### **A7: Control characteristics contact K2**

Independent choice of either PID or thermostatic characteristics for each contact. If contact K2 is set as PID-contact, it operates with setpoint 1.

### **A8: Display mode**

The value can be indicated in integrals or with decimals and with or without leading zeros. In general, all parameter indications are presented with decimals.

### **A9: Temperature scale**

Indication can be switched between Fahrenheit, Celsius and Kelvin. At conversion, the parameters and setpoints maintain their numerical value and adjustment range. (Example: A controller with the desired value of 0°C is switched to Fahrenheit. The new desired value is then interpreted as 0°F, which corresponds to a temperature of -18°C).

NOTE: Indication limits with °F can be smaller than the actual measuring range!

### **A10: Indication value for lower value linear analogue input**

### **A11: Indication value for upper value linear analogue input**

Only relevant, if the controller is programmed for a voltage input (0...10V linear) or a current input (4...20mA linear). These parameters allow scaling of the linear analogue input. The value to be indicated for the lower and upper entrance value then defines the range the controller will indicate. For input range 4...20mA the display will show sensor error if the input signal drops below 4mA.

### **A19 Parameter lock**

This parameter enables locking of each parameter level. If third level is locked, only parameter A19 may be changed.

### **A30: Function alarm exit**

The alarm exit evaluates an upper and a lower limit value (see parameters P30 and P31), whereas a selection is possible as to whether the alarm is active if the temperature lies within these two limits (range alarm), or whether the alarm is released if the temperature lies beyond them (boundary alarm). In the case of sensor error, the alarm is activated independently of this adjustment.

### A31: Special function at boundary or range alarm

Here can be selected whether, in the case of an alarm, the indication to flash and/or the buzzer is to start. Sensor alarm (display F1 or F2) is indicated independently thereof by flashing display and the buzzer.

### A32: Special display

This parameter permits a permanent special display in the upper or lower display. It is possible to indicate the setpoint, formed by reference variable and the given offset temperature, the desired difference value (if differential control) or the actual difference value. In this case, the usually indicated following or leading value is not available in the first parameter level.

Note: If desired difference value is selected and there is no differential control, the following value is indicated in the upper display and the lower display is off. The lower display stays off, if no special function is selected or if there is no differential control.

### A35: Adjustment of setpoint S1' (not available on all types of controllers)

The functions of this parameter are only effective if there is a switching input E1 available. By closing switching input E1, setpoint S1 can be switched to a setpoint S1'. Setpoint S1' can be either relative to the difference value or an independent, freely adjustable, difference value or an independent, freely adjustable setpoint. In case of a freely adjustable setpoint the leading value has no more influence on the setpoint and the respective sensor can be disconnected; an error message will be suppressed. The lower display remains deactivated as long as there is no special function set with parameter A32.

The setpoint S1' can only be indicated and adjusted if input E1 is closed.

### Status messages

Message	Cause	Error elimination
<b>F 1</b>	Sensor error (open- or short-circuit at sensor F1)	Check sensor
<b>F 2</b>	Sensor error (open- or short-circuit at sensor F2)	Check sensor
---	Keyboard lock active	see Parameter P19 or A19
<b>display flashing, buzzer</b>	Temperature alarm (see A31)	cancel buzzer with DOWN button
<b>EP</b>	Data loss at parameter memory (Contacts K1 and K2 are switched off)	If error cannot be eliminated by switching on/off, the controller must be repaired

## Technical data of ST96-35.04

### Input

**E1:** External potential-free switching input

### Measuring input

**F1:** Resistance thermometer Pt100-3L

**F2:** Resistance thermometer Pt100-3L

Measuring range: -200...850 °C

Measuring accuracy: 0.5 K or 1 K, affected by display resolution (without sensor)

### Outputs

**K1:** Relay, change-over contact, 7(1.5)A 250V~

**K2:** Relay, change-over contact, 7(1.5)A 250V~

**K3:** Relay, normally-open contact, 7(1.5)A 250V~

**K4:** Relay, normally-open contact, 1A 24V

### Display

2 4-digit LED-displays, height 13 mm and 10 mm, colour red.

3 LEDs, for status display of the outputs.

### Power supply

12-24V AC (50/60 Hz) or 16-36V DC

### Ambient conditions:

Storage temperature: -20°C...70 °C

Operating temperature: 0...55 °C

Relative humidity: max. 75 %, without dew.

### Weight

ca. 630 g without sensor.

### Enclosure

Front IP50, available with IP63.

### Installation data

Unit is to be installed in an instrument panel.

Front size: 96 x 96 mm

Panel cut-out: 90.5 x 90.5 mm

Installation depth: ca. 105 mm with connector